

**OPERATION MANUAL**

**UV INKJET PRINTER**  
***UJF-7151 plus***

**OPERATION MANUAL**

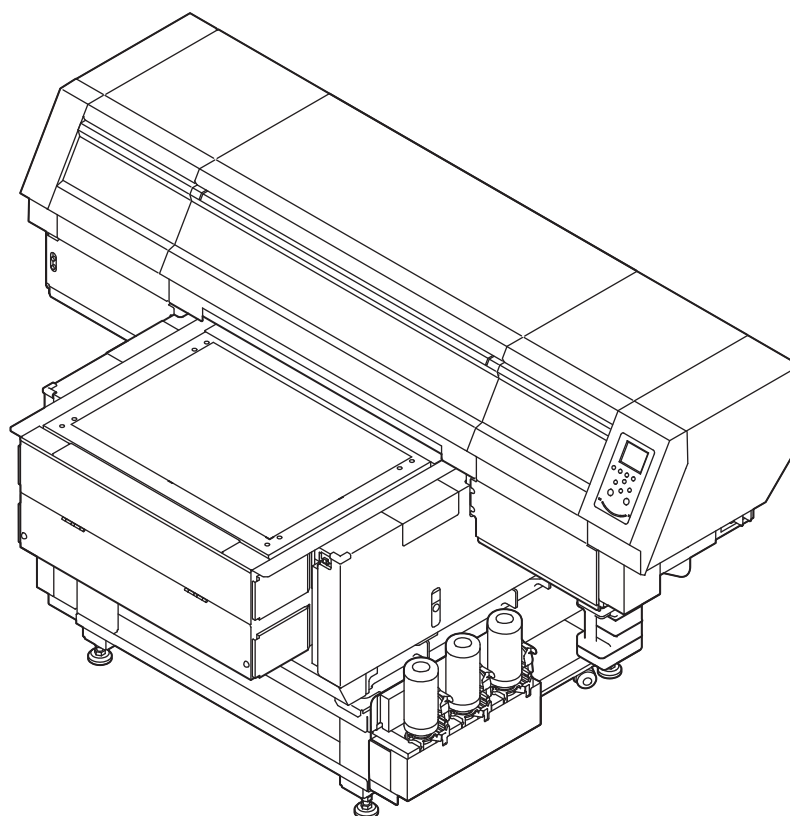

**MIMAKI ENGINEERING CO., LTD.**

URL: <http://eng.mimaki.co.jp/>

D202901-12

Original instructions

# TABLE OF CONTENTS

---

CAUTION .....	v
DISCLAIMER OF WARRANTY .....	v
Requests .....	v
FCC Statement (USA) .....	v
Interference to televisions and radios .....	v
CDRH REGULATION .....	v
Foreword .....	vi
On this operation manual .....	vi
For safe operation .....	vi
Symbols .....	vi
Position of the warning label .....	xii

## Chapter 1 Before Use

Installing the machine .....	1-2
Where to install the machine .....	1-2
Moving this machine.....	1-2
Configuration and Function .....	1-3
Front.....	1-3
Rear.....	1-4
Operation Panel .....	1-5
Carriage.....	1-6
About table .....	1-6
About tap position.....	1-6
Connecting the cables .....	1-7
Connecting the USB2.0 interface cable .....	1-7
Connecting the LAN cable.....	1-7
Connecting the power cable.....	1-8
About ink bottle .....	1-8
Kinds of ink that can be used .....	1-8
Caution in handling of ink bottles .....	1-9
Setting ink bottles .....	1-9
About Media .....	1-14
The sizes of media that can be used.....	1-14
Precautions in handling the media .....	1-14
Menu mode .....	1-14

## Chapter 2 Basic Operations

Operation flow .....	2-2
Turning the Power ON/OFF .....	2-3
Turning the Power ON.....	2-3
Turning the Power OFF.....	2-3
Setting the media .....	2-4
Set the media in another method .....	2-6
Test printing .....	2-6
Execution of head cleaning .....	2-7
Printing an image from source data .....	2-8
Starting the printing operation .....	2-8

Interruption of printing .....	2-8
Checking printing data that is being received or has been received ..	2-9
When [! WORK High] is displayed.....	2-9
If you open the cover during printing .....	2-9

## Chapter 3 Setup

About Head Height MENU .....	3-2
Head Height MENU table .....	3-2
Setting the Media Thickness .....	3-3
Setting the HEAD GAP .....	3-3
Gap check .....	3-3
About ORIGIN SETUP MENU .....	3-4
ORIGIN SETUP MENU table .....	3-4
Setting the X offset .....	3-5
Setting the Y offset .....	3-5
Setting the Z origin .....	3-5
Changing the origin using the JOG keys .....	3-5
About SETUP MENU .....	3-6
SETUP MENU table .....	3-7
Setting of Media Correction .....	3-8
Setting of LOGICAL SEEK .....	3-8
Setting of INK LAYERS .....	3-9
Setting of REFRESH LEVEL .....	3-9
Setting of PRIORITY .....	3-9
Setting of UV MODE .....	3-10
Setting of WORK CHANGE .....	3-10
Setting of FAN MODE .....	3-10
Setting of AUTO CLEANING .....	3-10
Setting of PRINT FLUSHING LEVEL .....	3-11
Setting of MAPS .....	3-11
Setting of the Misregistration adjust .....	3-12
About MACHINE SETUP MENU .....	3-13
MACHINE SETUP MENU table .....	3-14
Setting Time .....	3-15
Setting Unit (Temperature/ Length) .....	3-15
Setting a KEY BUZZER .....	3-15
Set the network .....	3-16
Setting event mail function .....	3-17
Setting a LANGUAGE .....	3-21
Initializing the Settings .....	3-21
About NOZZLE CHECK MENU .....	3-22
INFORMATION MENU table .....	3-22
Printing Check Flow .....	3-23
Printing Operations at “Nozzle Missing” Judgment and Error Occurrence .....	3-23
Setting the Printing Check .....	3-24
Setting the NOZZLE RECOVERY .....	3-24
Setting the Judgement Condition .....	3-24
About INFORMATION MENU .....	3-25
INFORMATION MENU table .....	3-25
Displaying the Information .....	3-26

---

## Chapter 4 Maintenance

Routine maintenance .....	4-2
When this machine is left unused for a long time .....	4-2
Precautions in cleaning .....	4-2
Cleaning exterior surfaces.....	4-2
Cleaning the table .....	4-3
About MAINTENANCE MENU .....	4-4
MAINTENANCE MENUs at-a-glance.....	4-5
Maintaining the Capping Station .....	4-6
Cleaning the Wiper and Cap .....	4-6
Washing the Ink Discharge Passage .....	4-7
Cleaning the Ink Head and the Area around It .....	4-8
Nozzle Recovery Function .....	4-9
Reset the set value.....	4-10
Checking the UV Lamp Usage .....	4-10
Setting Interval wiping .....	4-10
Changing the Time When a Warning about Wiper Replacement Is Issued.....	4-11
Checking the Head Gaps at the Four Corners of the Table .....	4-11
Checking Ink Landing Displacement.....	4-11
Solving the Ink Overflow Problem .....	4-12
Replacing consumables .....	4-12
If a Waste Ink Tank Confirmation Message Appears .....	4-12
Replacing the waste ink tank before the waste ink tank confirmation message is displayed .....	4-14
Refilling antifreeze mixed water .....	4-14
Refill antifreeze mixed water .....	4-15

## Chapter 5 Troubleshooting

Troubleshooting .....	5-2
Power does not turn on .....	5-2
The machine does not start printing.....	5-2
Image quality is poor .....	5-2
Nozzle is clogged .....	5-3
Ink bottle warning appears .....	5-3
Warning / Error Messages .....	5-4
Warning messages.....	5-4
Error messages.....	5-6

## Chapter 6 Appendix

Specifications .....	6-2
Machine specifications .....	6-2
Ink specifications.....	6-3
Setting orders of ink bottles .....	6-4
Sheet for inquiry .....	6-5



## CAUTION

### DISCLAIMER OF WARRANTY

THIS LIMITED WARRANTY OF MIMAKI SHALL BE THE SOLE AND EXCLUSIVE WARRANTY AND IS IN LIEU OF ALL OTHER WARRANTIES, EXPRESS OR IMPLIED, INCLUDING, BUT NOT LIMITED TO, ANY IMPLIED WARRANTY OF MERCHANTABILITY OR FITNESS, AND MIMAKI NEITHER ASSUMES NOR AUTHORIZES DEALER TO ASSUME FOR IT ANY OTHER OBLIGATION OR LIABILITY OR MAKE ANY OTHER WARRANTY OR MAKE ANY OTHER WARRANTY IN CONNECTION WITH ANY PRODUCT WITHOUT MIMAKI'S PRIOR WRITTEN CONSENT. IN NO EVENT SHALL MIMAKI BE LIABLE FOR SPECIAL, INCIDENTAL OR CONSEQUENTIAL DAMAGES OR FOR LOSS OF PROFITS OF DEALER OR CUSTOMERS OF ANY PRODUCT.

### Requests

- This Operation Manual has been carefully prepared for your easy understanding, however, please do not hesitate to contact a distributor in your district or our office if you have any inquiry.
- Description contained in this Operation Manual are subject to change without notice for improvement.

### FCC Statement (USA)

This equipment has been tested and found to comply with the limits for a Class A digital device, pursuant to Part 15 of the FCC Rules. These limits are designed to provide reasonable protection against harmful interference when the equipment is operated in a commercial environment. This equipment generates, uses and can radiate radio frequency energy and, if not installed and used in accordance with the operation manual, may cause harmful interference to radio communications. Operation of this equipment in a residential area is likely to cause harmful interference in which case the user will be required to correct the interference at his own expense.



- In the case where MIMAKI-recommended cable is not used for connection of this device, limits provided by FCC rules can be exceeded. To prevent this, use of MIMAKI-recommended cable is essential for the connection of this machine.

### Interference to televisions and radios

The product described in this manual generates low radio waves while it is in operation. The product can interfere with radios and televisions if set up or commissioned under improper conditions. The product is not guaranteed against any damage to specific-purpose radios and televisions.

The product's interference with your radio or television will be checked by turning on/off the power switch of the product.

In the event that the product is the cause of interference, try to eliminate it by taking one of the following corrective measures or taking some of them in combination.

- Change the direction of the receiving antenna or the feeder of your radio/television.
- Move the receiver away from the product.
- Plug the power cord of this machine into an outlet which is isolated from power circuits connected to the television set or radio.

### CDRH REGULATION

The Center for Devices and Radiological Health for the U.S. Food and Drug Administration Implement regulations for laser products. The sentence of "This product complies with 21 CFR chapter I and subchapter J" indicates compliance with the CDRH regulations and is labeled on the product when marketed in the United States. This Model is equivalent to Class II laser device according to CDRH Regulation.

This product complies with 21 CFR chapter I and subchapter J



- Use of controls, adjustments or performance of procedures other than those specified in this manual may result in hazardous radiation exposure.

## Foreword

Congratulations on your purchase of a MIMAKI "UJF-7151 plus" model of UV ink jet printer.

UV Inkjet Printer UJF-7151 plus uses ultraviolet ray curing ink (UV ink).

Read this Operation Manual carefully and make the most effective use of your printer.

### On this operation manual

- This Operation Manual describes the operation and maintenance of Model UJF-7151 plus Color Ink Jet Printer (hereinafter referred to as the machine).
- Please read and fully understand this Operation Manual before putting the machine into service. It is also necessary to keep this Operation Manual on hand.
- Make arrangements to deliver this Operation Manual to the person in charge of the operation of this machine.
- This Operation Manual has been carefully prepared for your easy understanding, however, please do not hesitate to contact a distributor in your district or our office if you have any inquiry.
- Description contained in this Operation Manual are subject to change without notice for improvement.
- In the case where this Operation Manual should be illegible due to destruction or lost by fire or breakage, purchase another copy of the Operation Manual from our office.
- You can also download the latest operation manual from our website.

## For safe operation











### Symbols





Symbols are used in this Operation Manual for safe operation and for prevention of damage to the machine.

The indicated sign is different depending on the content of caution.





Symbols and their meanings are given below. Please follow these instructions as you read this manual.









### Examples of symbols

Meaning	
	Failure to observe the instructions given with this symbol can result in death or serious injuries to personnel. Be sure to read it carefully and use it properly.
	Failure to observe the instructions given with this symbol can result in injuries to personnel or damage to property.
	Important notes in use of this machine are given with this symbol. Understand the notes thoroughly to operate the machine properly.
	Useful information is given with this symbol. Refer to the information to operate the machine properly.
	Indicates the reference page for related contents.
	The symbol "  " indicates that the instructions must be observed as strictly as the CAUTION instructions (including DANGER and WARNING instructions). A sign representing a precaution (the sign shown at left warns of hazardous voltage) is shown in the triangle.
	The symbol "  " indicates that the action shown is prohibited. A sign representing a prohibited action (the sign shown at left prohibits disassembly) is shown in or around the circle.
	The symbol "  " indicates that the action shown must be taken without fail or the instructions must be observed without fail. A sign representing a particular instruction (the sign shown at left instructs to unplug the cable from the wall outlet) is shown in the circle.

 <b>WARNING</b>	
	<ul style="list-style-type: none"> <li>• Be sure to setup the appropriate air-moving system in case of using this machine in a closed room or a room with bad ventilation.</li> <li>• Cautions for constructing exhaust outlet Please observe the following cautions to avoid breakdown of this machine.                             <ol style="list-style-type: none"> <li>(1) The opening area of the exhaust outlet requires more than half of the duct entrance area.</li> <li>(2) If mounting a valve on the exhaust outlet, be sure to open the valve when using the machine.</li> </ol> </li> </ul>
	<ul style="list-style-type: none"> <li>• The ink used for this machine falls into the category of UN No.3082 and UN Class 9. Since the ink is flammable, never use fire when using the machine.</li> </ul>
	<ul style="list-style-type: none"> <li>• When cleaning the ink station or the head, be sure to wear the supplied goggle and gloves since you may get ink or cleaning solution in your eyes.</li> </ul>
	<ul style="list-style-type: none"> <li>• If anyone swallows ink or cleaning solution in mistake, get the person to vomit and see a doctor immediately. Do not let him or her swallow the vomit. Then, refer MSDS about the inquiry.</li> <li>• If you inhale a lot of vapor and feel bad, immediately move to a location of fresh air and then keep yourself warm and quiet. Then, consult a doctor as soon as possible.</li> <li>• Discard the waste ink according to the local regulations of the area that this machine is used.</li> </ul>

### Never do the following

 <b>WARNING</b>	
<b>Do not disassemble or remodel the machine</b>	
	<ul style="list-style-type: none"> <li>• Never disassemble or remodel this machine and the ink bottle. Disassembling or remodeling any of them will result in electric shocks or breakdown of this machine.</li> </ul>
<b>Do not use this machine in damp places</b>	
	<ul style="list-style-type: none"> <li>• Avoid damp environment to use this machine. Do not splash water onto this machine. High humidity or water will give rise to fire, electric shocks or breakdown of this machine.</li> </ul>
<b>Wearing protective devices</b>	
	<ul style="list-style-type: none"> <li>• When cleaning the suction nozzle, which may scatter ink, be sure to wear safety glasses and gloves, or ink and cleaning solution might enter your eyes or ink and cleaning solution put on your hands might make your hands rough.</li> </ul>

 <b>WARNING</b>	
<b>Handling of ink bottles</b>	
	<ul style="list-style-type: none"> <li>• Some of the ingredients (UV Curing initiator) have toxic consequences to aquatic life. Avoid leak into water system or sewage containing water.</li> <li>• Store ink bottles and waste ink tank in a place that is out of the reach of children.</li> <li>• If ink settles on the skin or clothes, immediately wash it off with detergent or water. If you get ink in your eyes, immediately wash your eyes with a lot of clean water, and then consult a doctor as soon as possible.</li> </ul>
<b>Abnormal event occurs</b>	
	<ul style="list-style-type: none"> <li>• If the machine is used under an abnormal condition where the machine produces smoke or unpleasant smell, fire or electric shocks can result. Be sure to turn off the power switch immediately and detach the plug from the receptacle. Check first to be sure that the machine no longer produces smoke, and contact a distributor in your district for repair.</li> <li>• Never repair your machine by yourself since it is very dangerous for you to do so.</li> </ul>
<b>Power supply and voltage</b>	
	<ul style="list-style-type: none"> <li>• Use this machine with indicated power specifications. Be sure to connect the power cable plug to the grounded outlet, or it may cause fire or electric shock.</li> </ul>
	
	<ul style="list-style-type: none"> <li>• Never look at the LED UV being lit with your naked eyes, or it may cause pain in your eyes or visual impairment. Be sure to wear safety glasses.</li> <li>• Do not apply ultraviolet (UV) light directly to your skin, or it may cause irritation on your skin.</li> </ul>
	<ul style="list-style-type: none"> <li>• To prevent electrical shock, be sure to set OFF the main power circuit breaker and disconnect the power plug before carrying out maintenance. For some units, capacitors may take one minute for discharging; therefore, start maintenance work three minutes after setting OFF the main power circuit breaker and disconnecting the power plug.</li> <li>• If LED UV has been damaged, you should replace the LED UV that has reached or has past its rating life.</li> </ul>
	<ul style="list-style-type: none"> <li>• The main power circuit breaker should be set ON only by personnel with sufficient knowledge about operations of this machine.</li> <li>• Do not touch the lamp with bare hands while lighting or right after the lamp off to avoid from burn injury.</li> </ul>
<b>Handling of the power cable</b>	
	<ul style="list-style-type: none"> <li>• Use a power cable attached to this machine.</li> <li>• Take care not to damage, break or work on the power cable. If a heavy things are put on the power cable, heated or drawn, the power cable can break to cause fire or electric shocks.</li> </ul>



**WARNING****Handling of LED UV**

- Do not use the LED UV in an ambience with a possibility of catching fire (gasoline, combustible gas spray, thinner, lacquer, powder dust, etc.). In addition, do not put paper or cloth near or on the LED UV, or it may cause fire, or it may cause electrical shock.

**Handling of the antifreeze liquid**

- Use the exclusive antifreeze liquid, or the cooling device may be damaged.
- If the antifreeze liquid or mixed soft water with antifreeze liquid gets on the skin or clothes, immediately wash it off with soap. If you get the antifreeze liquid in your eyes, immediately wash your eyes with a lot of clean water. Then, consult a doctor as soon as possible.
- Before using the antifreeze liquid, be sure to read the Material Safety Data Sheet (MSDS).
- If you swallowed the antifreeze liquid accidentally, try to get to vomit, and then consult a doctor as soon as possible.
- Discard the waste antifreeze liquid or used mixed soft water with antifreeze liquid as follows; Absorb in a sawdust or waste cloth, then incinerate it.
- Entrust to an industrial waste disposal contractor, clarifying their contents.
- Avoid causing ignition with static electricity, impact spark and so on.
- Be sure to wear goggles and gloves for handling the antifreeze liquid.

**Precautions for use****CAUTION****Protection against dust**

- It is strongly recommended to use the machine in a room that is not dusty. Set the Refresh level 2 or 3 when in bad environment.
- When leaving the work place after the working hours, be sure to remove media from the printer. If any media is left on the printer, dust can put on it.
- Store media not to put dust on it. Wiping dust off the media, dust will be put on the media due to static electricity.
- Due to the dust on the head, ink drops will fall down on the media during printing. If so, be sure to clean up the head. (P.2-12)

**Periodic exchange parts**

- There are some parts which must be periodically replaced. Contract with distributors or dealers for maintenance.

**CAUTION****Ink bottles**

- If the ink bottle is moved from a cold place to a warm place, leave it in a place of use for three hours or more and use it.
- Open the ink bottle just before installing. Leaving it open for a long time will cause abnormal printing.
- Be sure to store ink bottles in a cold and dark place.
- Once the ink opened, be sure to use ink up early. The ink passed for a long time after opening the bottle will lower the printing quality.
- Using other than exclusive ink will break this machine. In this case, repairing of this machine is your responsibility.
- Never refill the ink bottle with ink.
- Do not pound the ink bottle nor shake it violently. If so, ink may leak out of the bottle.

**UV light**

- A little UV light spills around the LED UV unit. UV light applied to your skin might cause inflammation and/or skin cancer. Even weak UV light causing no inflammation may lead to chronic disorders by repeated exposure. Avoid applying UV light to your skin and eyes.



- Impairment of eyes caused by UV light may be acute disorders, pain in eyes, tearing, chronic disorders, cataract, etc. When using this machine, protect your body such as gloves, long-sleeve cloth, light-resistant mask, attached light-resistant glasses, etc.

**Hot parts**

- The LED UV and the interior of the UV irradiation device will have a very high temperature. When carrying out maintenance, wait until the temperature has been sufficiently lowered after the lamp is turned OFF.



- When it is unavoidable to touch hot parts, be sure to wear heat-insulating gloves to protect your hands.

**Warning labels**







- Warning labels are adhered on this machine. Be sure to fully understand the warnings given on the labels. In the case where any of the warning label has become so soiled that the warning message is illegible or has come off, purchase a new one from your local distributor or our office.

**Periodic exchange parts**

- There are some parts which must be periodically replaced. Contract with distributors or dealers for maintenance.

**Adjusting the level**

- Keep this machine horizontal.

 <b>CAUTION</b>	
<b>Handling of cleaning solution</b>	
	<ul style="list-style-type: none"> <li>• Be sure to store the cleaning solution in a cold and dark place. Store the cleaning solution in a place that is out of the reach of children.</li> </ul>
<b>Handling the antifreeze liquid</b>	
	<ul style="list-style-type: none"> <li>• Be sure to store the antifreeze liquid in a cold and dark place.</li> <li>• Store the antifreeze liquid in a place that is out of the reach of children.</li> </ul>
<b>Notes on LED UV</b>	
	<ul style="list-style-type: none"> <li>• When handling the glass on the bottom of the LED UV unit, be sure to wear the gloves attached and never touch them with bare hands. Or the UV ink curing level may significantly lower. If the glass becomes dirty, wipe it with clean gauze moistened with alcohol. (Do not use alcohol for cleaning the exterior cover, or the paint will peel off.)</li> </ul>
	<ul style="list-style-type: none"> <li>• The LED UV performance and service life are significantly affected by the UV irradiation and UV power supply units used. Never use those UV devices other than those recommended by Mimaki. We would take no responsibility for any troubles caused through the use of a UV devices not recommended by Mimaki.</li> </ul>
<b>Cleaning</b>	
	<ul style="list-style-type: none"> <li>• After using this machine long time, foreign materials and dust may be gathered on the conductive and insulating parts, causing electric leakage. Periodically clean such parts.</li> <li>• For cleaning, do not use compressed air because it scatters foreign materials and dust, which may cause malfunctions when put inside the conductive parts. Be sure to use vacuum cleaner to vacuum off foreign materials and dust.</li> <li>• Do not use the machine in a place where there is a possibility of being wet, or electricity may leak.</li> <li>• Electrical leakage may lead to electrical shock of personnel or fire.</li> <li>• To prevent accidents, be sure to carry out periodic inspections and replace periodic replacement parts.</li> </ul>
<b>Firing and smoking</b>	
	<ul style="list-style-type: none"> <li>• Touching hot parts such as the LED UV with combustible materials may cause firing and/or smoking.</li> </ul> <p>Leaving combustible materials under the LED UV unit for a couple of minutes may also cause firing and/or smoking.</p>

**CAUTION**

- After this machine is used long time, foreign materials or dust gathered may cause electrical leakage, or insulation deterioration may cause firing and/or smoking. Periodically clean this machine and replace the deteriorated parts after the insulation resistance.
- After this machine is used long time, screws or others on the conductive parts may be loosened, causing firing and/or smoking. Periodically tighten the screws.
- If abnormalities such as a strange odor, a smoking or a spark burn occurred, turn the power off and call our office immediately.

**Laser Module**





- The printer incorporates a laser module. The laser module is evaluated as Class 1 Laser Products.
- Use of controls or adjustments or performance of procedures other than those specified herein may result in hazardous radiation exposure.

Laser Diode 655 - 660nm, max. 0.5mW  
 Maximum output : 0.12 mW  
 IEC60825-1: 2007

クラス1レーザー製品

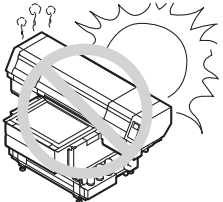
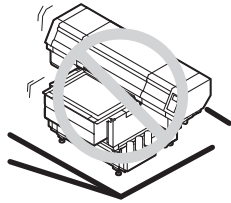
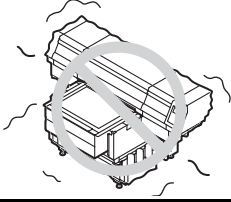
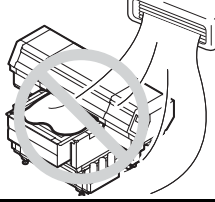
CLASS 1 LASER PRODUCT

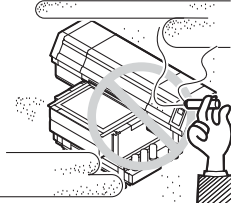
## Cautions on Installation

 <b>CAUTION</b>	
<b>A place exposed to direct sunlight</b>	<b>On an inclined surface</b>
	
<b>A place that vibrates</b>	<b>A place exposed to direct air flow from an air conditioner or the like.</b>
	
<b>A place where temperature or humidity varies significantly</b>	<b>Around a place where fire is used</b>
<p> •Use the machine under the following environmental conditions:</p> <ul style="list-style-type: none"> <li>• Operating environment: 20 to 30 °C (68 to 86 °F) 35 to 65 % (Rh)</li> </ul>	







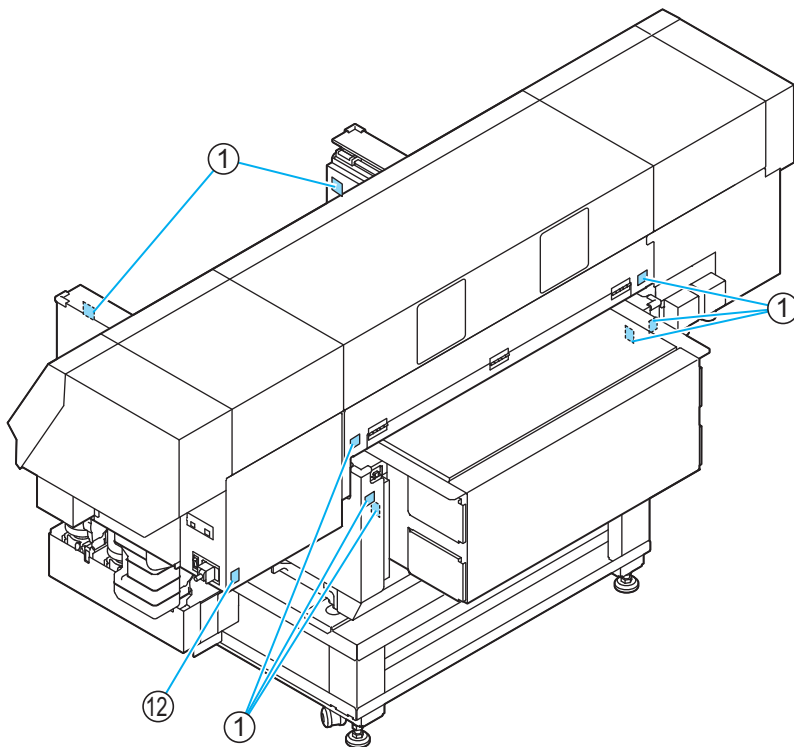
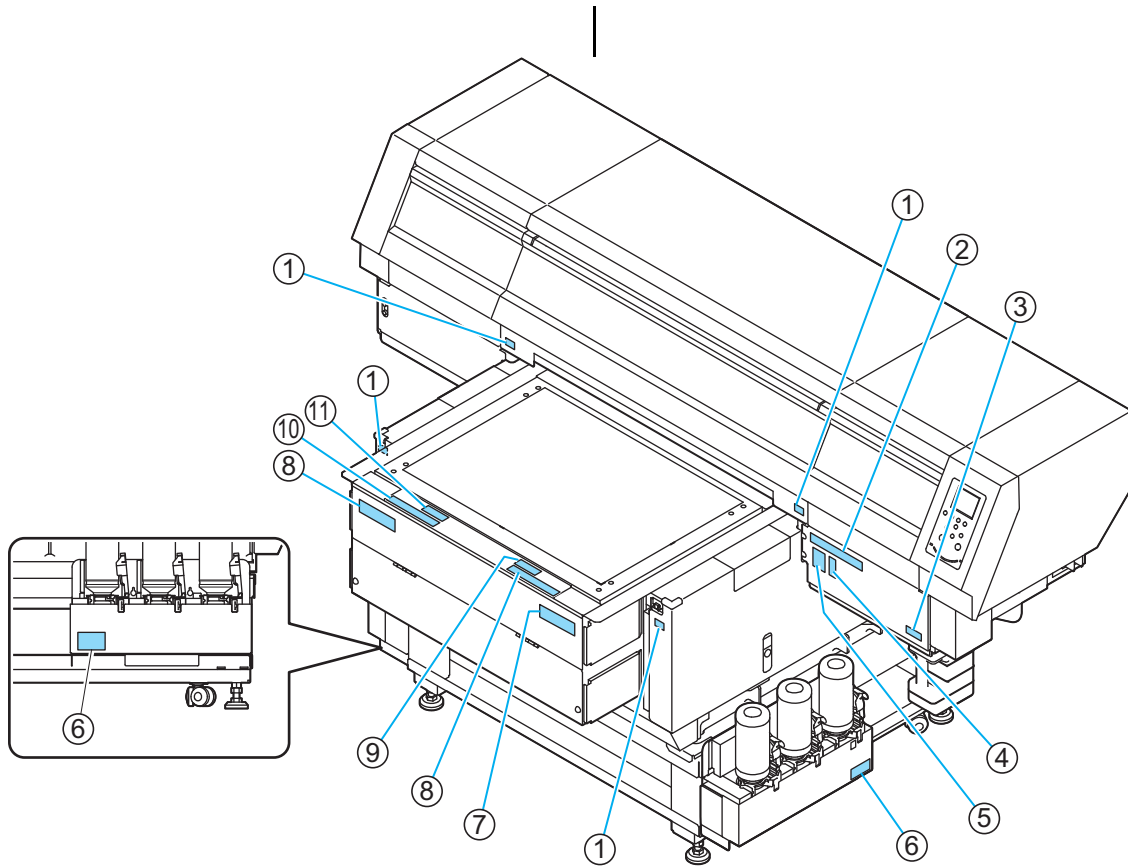

## Position of the warning label

Warning labels are adhered on this machine. Be sure to fully understand the warnings given on the labels.

In the case where any of the warning label has become so soiled that the warning message is illegible or has come off, purchase a new one from your local distributor or our office.

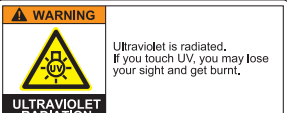

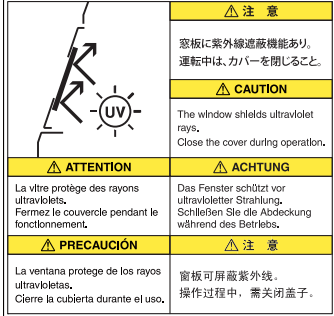
Order No.	Label	Order No.	Label
-----------	-------	-----------	-------

(1)M910540		(6)M906222	
(2)M901549		(7)M906115	
(3)M903330		(8)M903226	<p>このテーブルに懸掛けたり、寄り掛かる等の過荷重をかけないで下さい。 テーブルが変形し、故障の原因や、画質に影響が出る可能性があります。</p>
(4)M905980		(9)M912568	<p>テーブル上に 10kg 以上のものを 載せないで下さい。</p>
		(10)M904325	<p>Do not sit or lean on the table. Do not put any pressure on one side. These will deform the table and may cause damage and affects the printing.</p>
		(11)M912569	<p>DO NOT PUT OVER 10KG ON THE TABLE</p>
(5)M910560		(12)M907935	





# Chapter 1

## Before Use



### This chapter

describes the items required to understand before use, such as the name of each part of the machine or the installation procedures.

Installing the machine .....	1-2	About ink bottle .....	1-8
Where to install the machine .....	1-2	Kinds of ink that can be used .....	1-8
Moving this machine .....	1-2	Caution in handling of ink bottles .....	1-9
Configuration and Function .....	1-3	Setting ink bottles .....	1-9
Front .....	1-3	About Media .....	1-14
Rear .....	1-4	The sizes of media that can be used .....	1-14
Operation Panel .....	1-5	Precautions in handling the media .....	1-14
Carriage .....	1-6	Menu mode .....	1-14
About table .....	1-6		
About tap position .....	1-6		
Connecting the cables .....	1-7		
Connecting the USB2.0 interface cable .....	1-7		
Connecting the LAN cable .....	1-7		
Connecting the power cable .....	1-8		

# Installing the machine

## Where to install the machine

Secure sufficient space for installation before assembling this machine.

Decide the place considering the size of the machine and a space required for printing.

Model	Width	Depth	Height	Total Weight
UJF-7151 plus	2,193 mm	1,572mm	1,273mm (Including dedicated stand)	Approx.310 kg

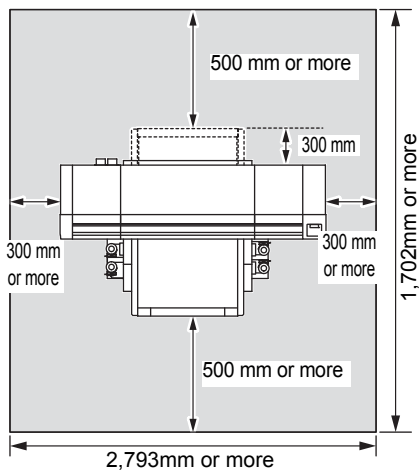

## Moving this machine

Move this machine as follows when this machine is required to move on the step-free same floor.



- When moving this machine, take care not to give a significant impact on it.
- When moving this machine, keep it as flatly as possible. Do not move it on its side. It may cause machine failure.
- The dedicated stand of this machine includes leveling feet to secure the machine. Before turning the power ON, make sure that the printer body is fixed with the leveling feet. The printer body may start moving during operation if it is not fixed with the leveling feet.

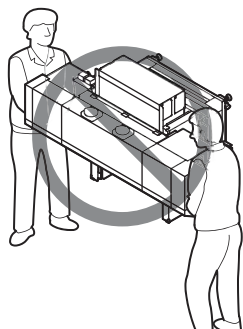

## Before moving this machine, install the handles for transporting. (two places)

Insert the handles into this machine, and fix them tightening screws.

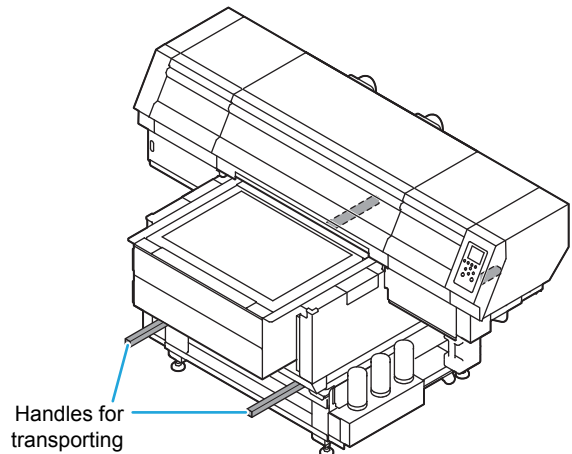

## For safety, be sure to work it with more than 8 people.

Do not push the cover to move this machine since the cover may be deformed. Be sure to hold the handles for transporting when moving the machine.

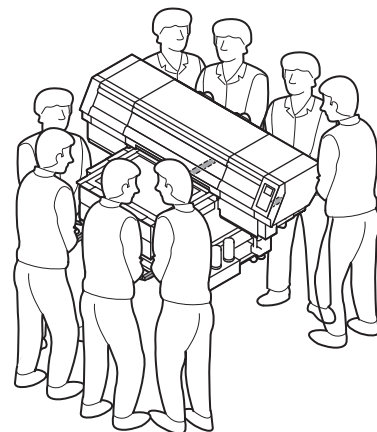

# Configuration and Function

## Front

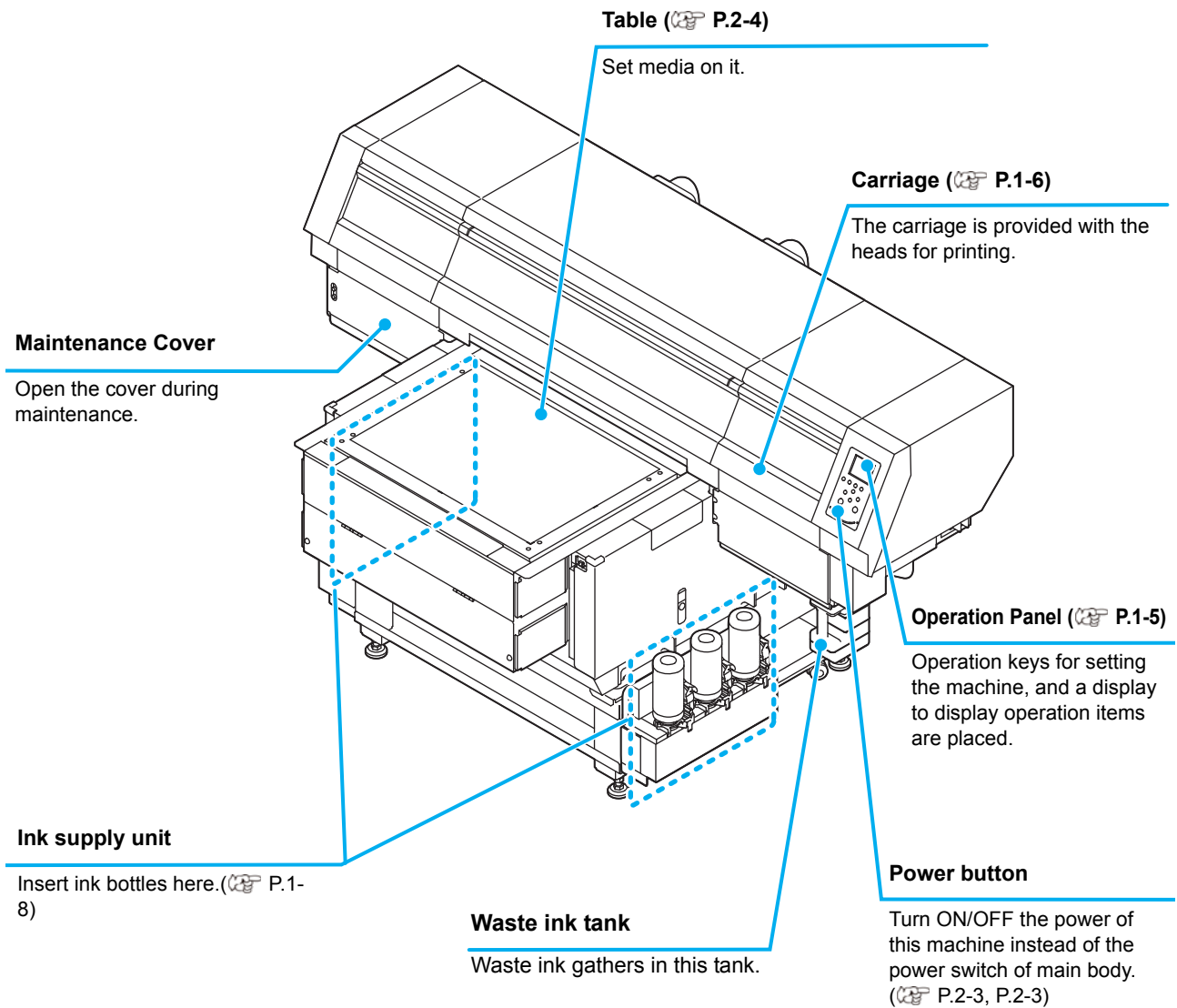

Rear

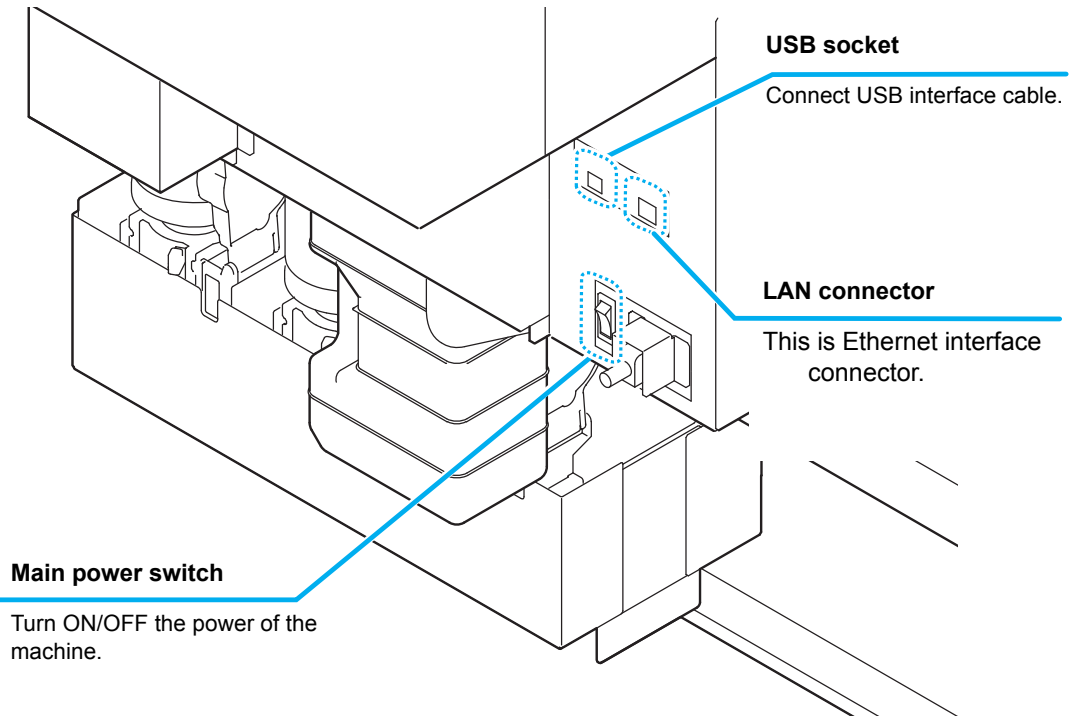

## Operation Panel

The operation panel is used for setting of printing method and each operation.

### **SEL** key

Changes over the functions of the function keys ([FUNC1]–[FUNC3]).

### **FUNC1** / **FUNC2** / **FUNC3** key

Press this to set various functions or to do test printing. The function keys' functions are changed each time [SEL] key is pressed.

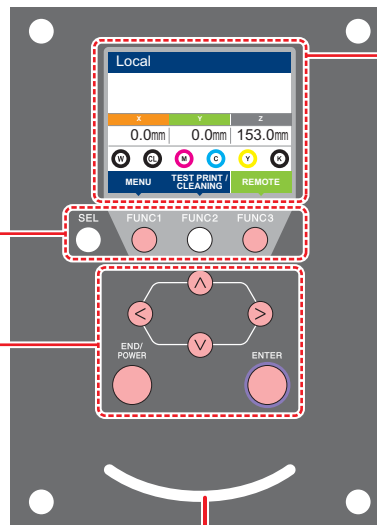

### Display

Displays the following items:

- Printer status
- Ink status
- Functions assigned to [FUNC1] to [FUNC3]

### **JOG** key

Use these keys to shift the carriage or the media in [LOCAL]. Also use them to select an item of printing conditions.

### **END/POWER** key

Cancels the last input value or returns the setting menu to the immediate higher level of the hierarchy. Also, press this to turn the power on or off. (Give it a long press to turn the power off.)

### **ENTER** key

Registers the last input value as the setting value or goes to the immediate lower level of the hierarchy.

### Status indicator lamp

Indicates the machine's status (printing, error occurred, etc).

Condition of Lamp	Condition of machine
OFF	Machine is in LOCAL mode, no print data has been received, and no errors have occurred.
Lit steady Light blue	Switched to Remote mode.
Flashing Light blue	Currently printing.
	In test printing: printing a pattern stored inside the machine.
Lit steady blue	Print data still remains in the machine.
Flashing red	Error has occurred.
Lit steady red	Error (SYSTEM HALT) has occurred.



- The [ENTER] key under the operation panel lights in blue when the power is turned on, and off when the power switch is turned off. The ink clogging prevention function is periodically operated even when the power switch is OFF if the main power switch keeps being ON. (Auto maintenance function)  P.1-4

## Carriage

A print head for printing, LED UV device, and a light pointer in the print head cover are mounted on the carriage.

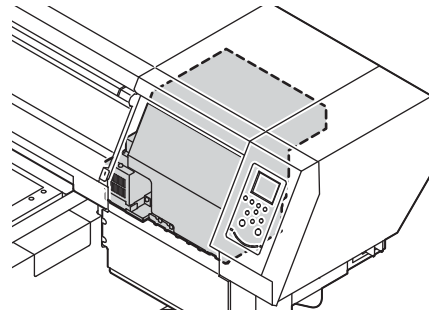

## About table

It is necessary to adjust the table height depending on the media thickness because various media can be set for printing.

The specification of each table is as less:



	Table
Acceptable media weight *1	10kg and less
Vacuum function	Yes
Table movable area	0 to 153mm
Media thickness	0 to 153mm

\*1. If you put a heavier thing than specified, the quality image may be degraded.

## About tap position

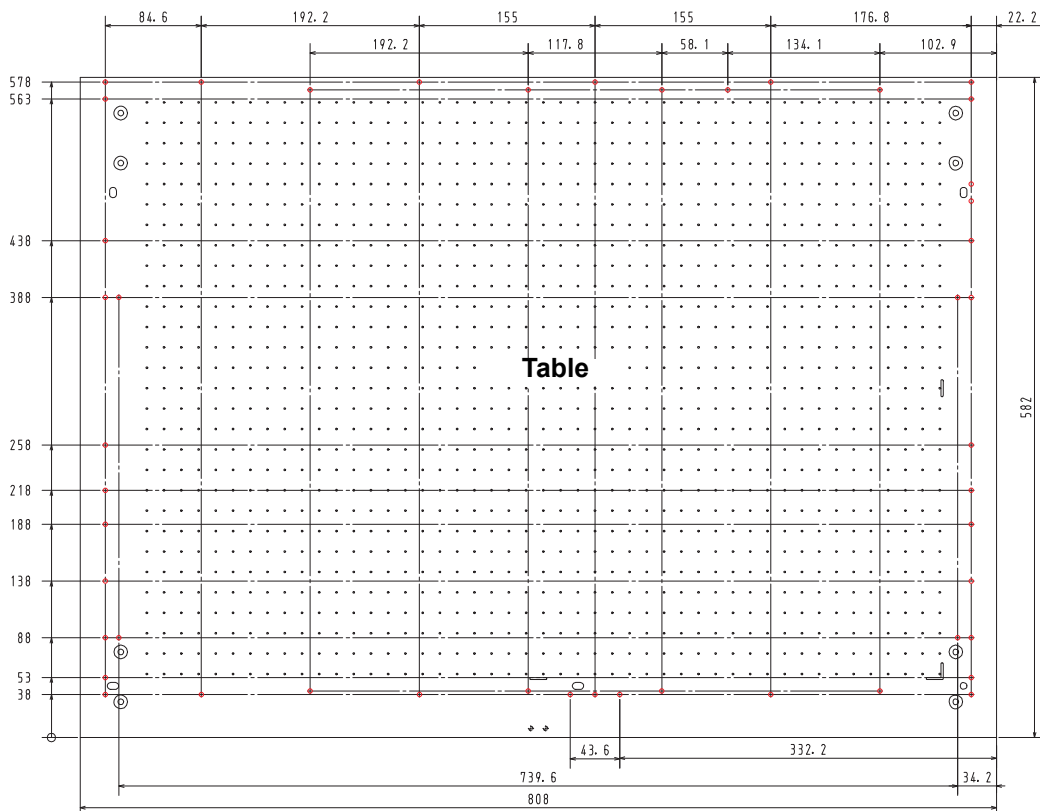
The table and the vacuum table on which the media set have the M4 tap (47 positions) of the size below respectively.



- Although tap holes are open except the tap position in the printing (  ), they are necessary in the production process. Therefore, please do not use them.
- We may change the position except specified tap holes (  ) without prior notice.

# Connecting the cables

## Connecting the USB2.0 interface cable

Connect a computer to this machine with the USB2.0 interface cable.



- Prepare the USB2.0 interface cable. (USB2.0 interface cable is not supplied with this machine.)
- Your RIP is required to support USB2.0 interface.
- If USB2.0 interface is not installed in your computer, ask a RIP maker near you or our branch office.

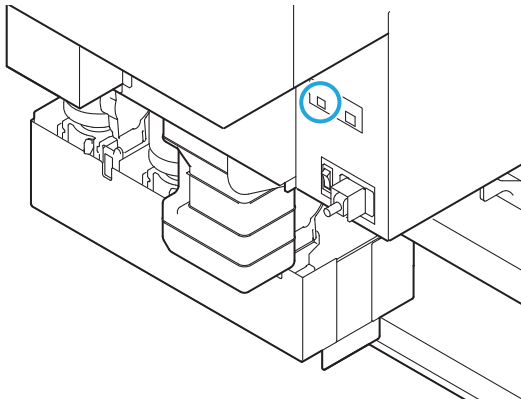

## Notes on USB 2.0 Interface



- Your RIP must be compatible with USB 2.0.

### ● When two or more UJF-7151 plus machines are connected to one personal computer

When two or more UJF-7151 plus machines are connected to one personal computer, the personal computer may not recognize all the UJF-7151 plus machines normally.

Reconnect the unrecognized UJF-7151 plus machine to another USB port, if available, and check to see if it is recognized. If the UJF-7151 plus machine is not recognized by the newly connected USB port, use USB 2.0 repeater cables available on the market.

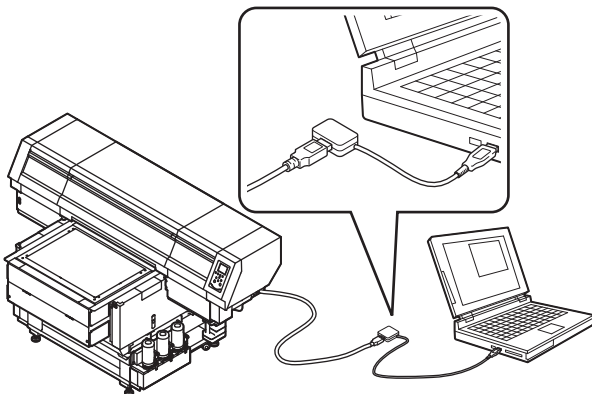

### ● Notes on peripheral devices in USB high speed mode

When a peripheral device (USB memory or USB HDD) to be operated in USB high speed mode is connected to the same personal computer that a UJF-7151 plus machine is connected to, the USB device may not be recognized. When UJF-7151 plus is connected to the personal computer to which an external HDD is connected via USB, the speed of data output to UJF-7151 plus may drop. That can cause the head unit to stop temporarily at the right or left end during printing.

### ● Removing USB memory

If a USB memory module is inserted in the personal computer to which a UJF-7151 plus machine is connected, click "Stop" in the "Safely Remove Hardware" window by following the instructions given there first and then remove the module.

Leaving a USB memory module inserted can cause [ERROR 10 COMMAND ERROR].

Copy the data onto the hard disk before outputting it for printing.

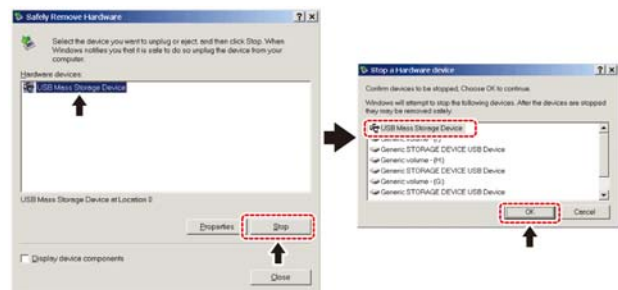

## Connecting the LAN cable

When connecting LAN cable, be sure to follow the note below:



- Surely insert LAN cable until clicking noise sounds.
- Do not plug in or unplug any cable during data transferring.

## Printing Via a Network

If printing via a network, you need to configure your network with the following environment.

If you configure it with an inappropriate environment, it could cause printing to stop.

- Use LAN cables that are category 6 or higher.
- Use a switching hub and PC that support 100BASE-T.



- Set the PC sending the print data and the printer to the same network.
- You cannot connect via a router.

### ● If connecting directly to the printer

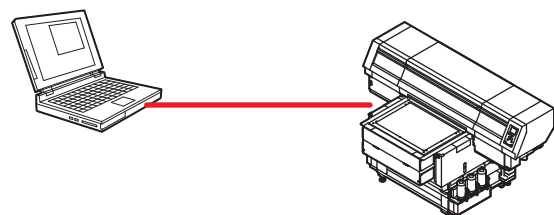

● If connecting via a switching hub

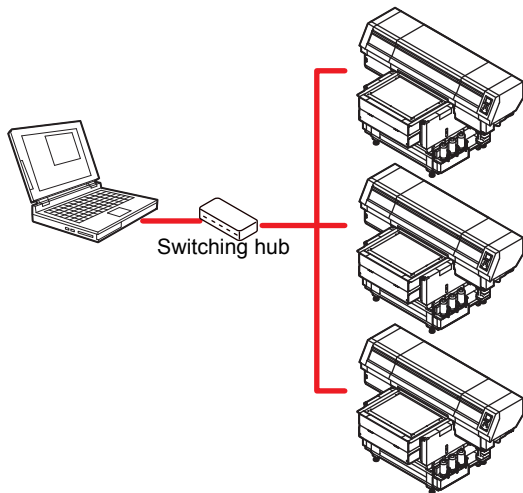

If the PC or device connected to the printer is not 1000BASE-T, you cannot perform printing. After connecting, check the following.

- (1) Check the printer screen display.
  - On the local screen or the media detection screen, press the [Enter] key several times to display the information screen.
- (2) Check the green light of the LAN connector.
  - After turning on the machine, the lamp for the LAN connector will light up as follows.

Color	Lit?	Condition
Green	ON	Connected with 1000BASE-T
	OFF	Connected without 1000BASE-T
Yellow	ON	Link-up
	Blinking	Receiving data
	OFF	Link-down

**Important!** • If the yellow light only lights up, or is blinking, the status is not 1000Mbps. Check the specifications of the PC, device, and cables.

### Connecting the power cable



- Use only the supplied power cable.
- Be sure to connect the power cable plug to the grounded outlet, or it may cause fire or electric shock.
- Take care not to damage, break or work upon the power cable. Or if putting a heavy thing on, heating, or pulling the power cable, the power cable can break to cause fire or electric shocks.

## About ink bottle

Use the ink bottle inserting it into the ink station. Three ink bottles are located on both the right and left sides.

### Kinds of ink that can be used

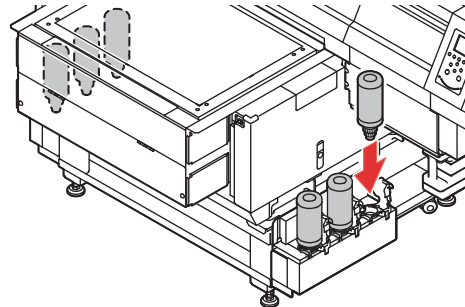

Ink Type	Color
UV Ink	Magenta
	Cyan
	Yellow
	Black
	White
	Clear
	Primer
Cleaning bottle *1	

\*1. To be used when the head is cleaned.

Each color is displayed on the LCD as follows:

Display	Color	Display	Color	Display	Color
M	Magenta	K	Black	P	Primer
C	Cyan	W	White		
Y	Yellow	CL	Clear		

### Precautions at the time of setting the ink bottle

When setting the ink bottle, pay attention to the followings:



- Confirm the ink slot number and insert the ink bottle of the correct color.
- Insert the ink bottle securely all the way in the slot. Moreover, do not insert or pull out the bottle roughly.
- Insert the bottle making the IC chip side facing upward.
- For replacing the ink bottle and the ink type, see the page below.  
( . . . P.1-8 "About ink bottle")



## Caution in handling of ink bottles



- If you get ink in your eyes, immediately wash your eyes with a lot of clean running water for at least 15 minutes. In doing so, also wash the eyes to rinse ink away completely. Then, consult a doctor as soon as possible.
- Use genuine ink bottles for this machine. This machine functions by recognizing the genuine ink bottles. In case of troubles caused by modified ink bottles or the like, it shall be out of the warranty even within the warranty period.
- Store the ink bottle in a place not more than 1 m off the ground. If you store it in a place higher than 1 m, should the ink bottle fall, the cap may come off, spilling the ink.
- If the ink bottle is moved from a cold place to a warm place, leave it in the room temperature for three hours or more before using it.
- Make sure to store ink bottles in a cool and dark place.
- Store ink bottles and waste ink tank in a place that is out of the reach of children.
- Some component (photoinitiator) of the ink is toxic against aquatic organisms. Avoid leakage of it to natural water system or domestic waste water.
- Before using an ink bottle, be sure to read the Safety Data Sheet (SDS).
- Request an industrial waste processor for processing of empty ink bottles.



- Do not shake ink bottles violently. This may result in ink leakage from the ink bottles.
- Never refill the ink bottles with ink. This may result in troubles. MIMAKI will not bear any responsibility for any damage caused by the use of the ink bottles refilled with ink.
- Do not touch or stain the contacts of the IC chip. This may cause damages on printed circuit boards.



- The shape of an ink bottle installed in the machine might collapse as shown in the figure on the right. This is normal, and does not affect the use or operation of the machine.

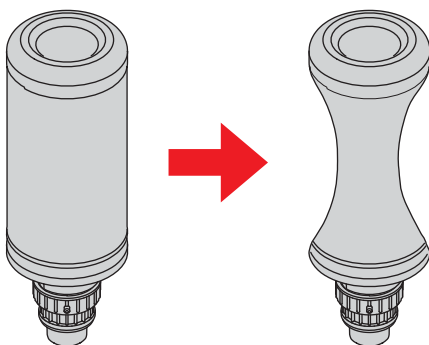

## Setting ink bottles

### 1

#### Take out the ink bottle, and slowly shake it twenty times and more.

- To prevent ink from leaking when you shake it, wear gloves and cover the ink bottle cap with a paper towel etc. Being in that status, slowly shake it twenty times and more by flowing ink.



- Before shaking it, check that the cap is firmly closed.
- If you shake it too strong, it may cause ink leakage. Therefore, perform this carefully.
- If the remaining amount of ink is less, ink in the bottle cannot be beaten enough. Tilt the ink bottle until it becomes vertical.

#### Cover with paper towel firmly and shake ink slowly

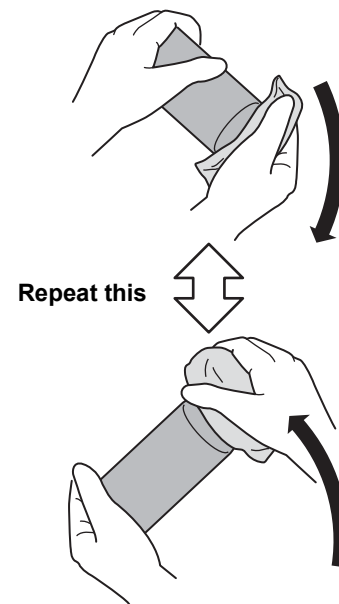

### 2

#### Remove the cap of the ink bottle.



**Important!**

- After the cap is removed, if a seal is attached to the mouse of the bottle, open the seal using a cutter knife. When opening the seal, make four slices (eight sections) as shown in the figure below and fold the flaps into the bottle.
- Fold the seal flaps fully and firmly into the inside of the bottle. If they are not sufficiently folded in, ink supply deficiency could result.

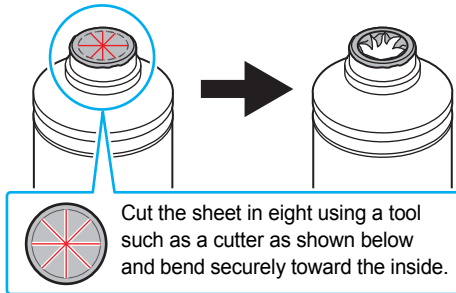

**3 Attach the specialized cap to the ink bottle.**  
 (1) Set the specialized cap on the bottle.

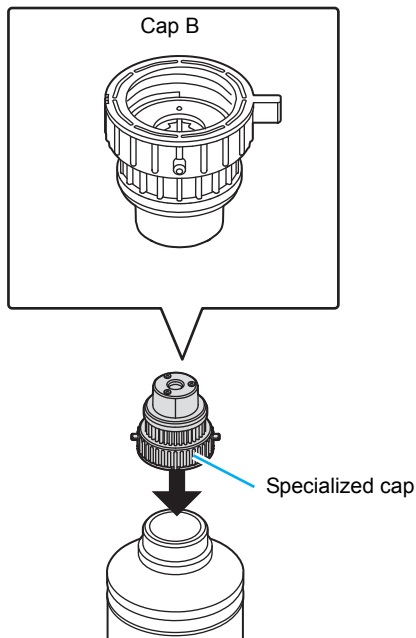

(2) Tighten the specialized cap using the tightening jig.

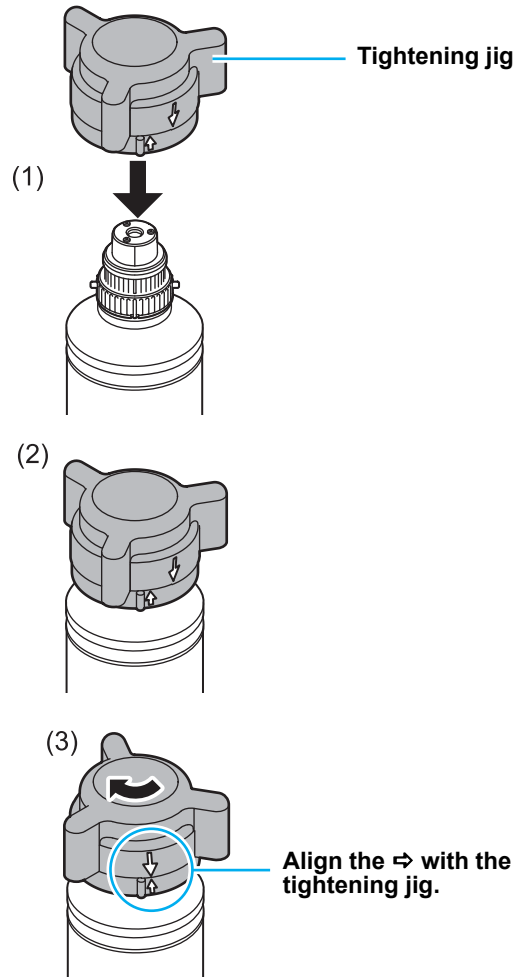

- Tighten until the arrows on the tightening jig are aligned.
  - Do not tighten the dedicated cap too
- (3) Turn the bottle upside-down and check that ink does not leak.



**Important!**

- Do not leave an ink bottle with the specialized cap attached in a location where it is exposed to light for a long period of time. Doing so can result in the ink in the bottle curing (hardening).

## 4 Set the ink bottle on the tank.

- Set the ink bottle while moving the lever on the tank completely to the right.



- Do not ever rotate the ink bottle at all after setting it into the tank.  
Doing so can result in ink leakage.

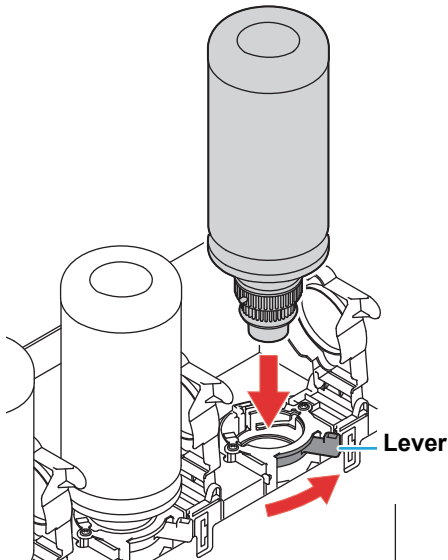

## 5 Move the lever on the tank completely from the right to the left side.

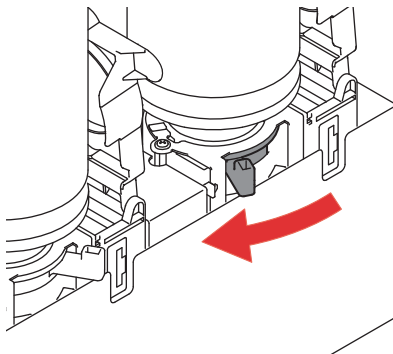

## 6 Insert the IC chip.

- Insert the IC chip with the left side with metal upward. If you insert the wrong side by accident, it causes faulty or damage of the IC chip.
- Do not touch the metal part of the IC chip. It may break the IC chip by static, or may cause read error by stain or flaw.
- For the setting orders of the ink bottles, refer to P.6-4.

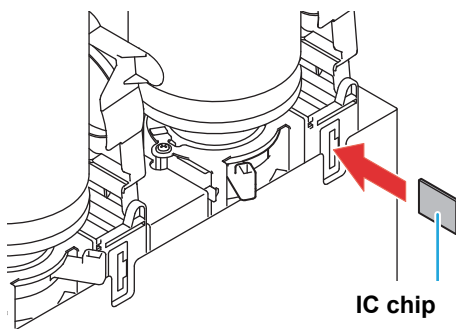

Important!

### About IC chip

- The IC chip has information of ink color, remaining amount of ink, expiration data, etc. When setting the ink bottle, insert the IC chip packed with the ink bottle into the IC chip inserting port attached with the ink cover.
- If you set the IC chip not being the pair of the ink bottle, image quality defect etc. may occur.
- The mark indicating color information is pasted on the IC chip.

### IC chip

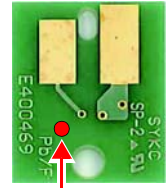

Mark indication position

### Ink color and indication mark

Ink color	Indication mark
Black	● (one black circle)
Cyan	● (one blue circle)
Magenta	● (one red circle)
Yellow	● (one yellow circle)
White	○ (one white circle)
Clear	○○ (two white circles)
Primer	○○○ (three white circles)

## Replace the ink bottle

Perform as follows when [INK END] or [INK NEAR END] is displayed on the display.

### ● When [INK END] is displayed

#### 1 Move the lever on the tank completely from the left to the right end.

- Important!** • Do not ever rotate the ink bottle at all after setting it into the tank. Doing so can result in ink leakage.

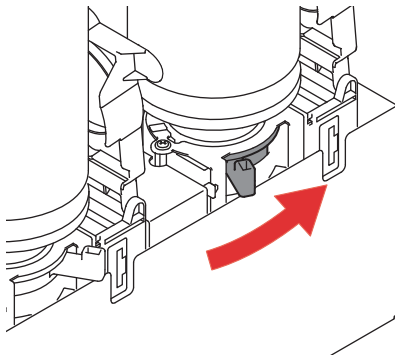

#### 2 Lift out the ink bottle while keeping it completely straight.

- Important!** • Check that the light-blocking cover closes when removing the ink bottle from the tank. Close by hand if the cap does not close. Leaving the light-blocking cover open can result in the ink curing.

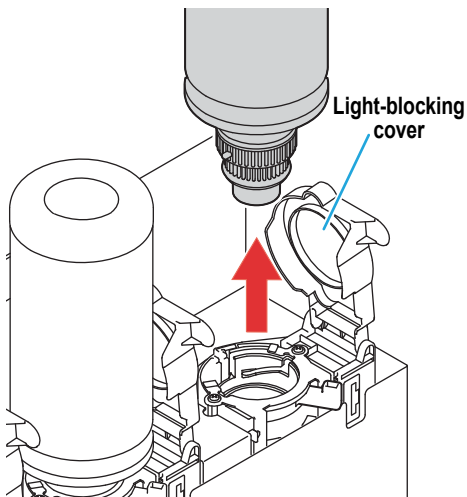

#### 3 Wipe off any ink adhering to the cap.

- (1) Set the bottle with cap upright and use a disposable wipe or similar item to wipe off any ink adhering to the cap.



#### 4 Remove the cap from the used ink bottle.

- Use the tightening jig to remove the cap if it is difficult to remove.

#### 5 Refer to P.1-9 "Setting ink bottles" to set the new ink bottle.

- Important!** • Do not leave an ink bottle with the specialized cap attached in a location where it is exposed to light for a long period of time. Doing so can result in the ink in the bottle curing.

### ● When [INK NEAR END] is displayed

There is a little of ink left. It is recommended to replace the ink bottle soon since ink may become empty in printing while printing is continuously enabled.

When you press the **ENTER** key in LOCAL, you can check the bottle to be replaced in the local guidance. (P.3-26)

## If the light-blocking cover comes off

If the light-blocking cover comes off, light striking the inside of the tank can result in the ink curing. Perform the following procedures if the light-blocking cover comes off.

- 1** Insert the nub (on one side) of the light-blocking cover into the hole on the tank.

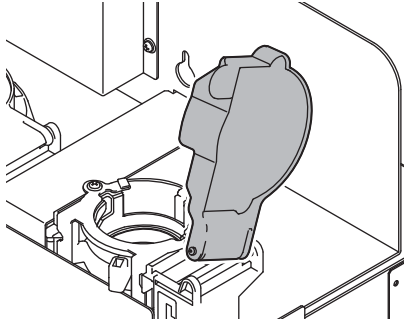

- 2** While pressing towards the side of the inserted hole of Step 1, insert the other nub into the other side.

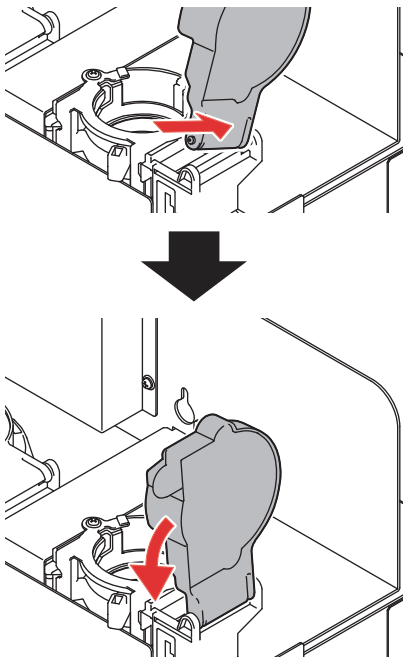

## About ink expiration date

The ink bottle has its expiration date.

You can use the bottle in two months after the expiration date indicated on it, however, you cannot use it when three months have passed from the expiration date.

When the ink bottle becomes unusable, a warning message appears. Replace it with a new one.

Ex.) When the expiration date is April 2012

May : Usable

June: Usable

July : Unusable

## About ink end and ink near end

When very little ink remains in the ink bottle, the warning message "INK NEAR END" appears. It is recommended that you replace the ink bottle with a new one as soon as you can.

When no ink remains in the ink bottle, the warning message "INK END" appears. Replace the ink bottle with a new one.

## About Media

The sizes of media that can be used and the method of handling are described here.

### The sizes of media that can be used

Maximum width	712mm
Maximum length	510 mm
Max. printing width	712mm
Max. printing length	520 mm
Thickness	153mm or less
Weight *1	10 kg

\*1. A rough guide is 27kg per 1 m<sup>2</sup>.

### Precautions in handling the media

Carefully observe the following when handling the media.



- **Extension and shrinkage of the media**  
Do not use the media in the sheet form shortly after the package was opened. The media could extend or shrink depending on the temperature and humidity inside the room. For more than 30 minutes after opening of the package, the media has to be exposed to the ambient air of the location it is to be used.
- **Warping of the media**  
As for the media of the sheet form, use the flat one, or the one warping downward (the one with floating central part when placed the printing surface facing upward.) Store the media liable to be warped on the slightly smaller platform or palette so that it may warp downward.
- **Other precautions**
  - c Do not place any article on the surface of the coated paper. Some coated paper could change its color.
  - d Curled media that cannot be absorbed or the media that misaligns when the Y-bar is moved may not be used. Before using, fix the media with adhesive tape, etc.
  - e Do not use the media that will generate warping or deformation.

## Menu mode

This machine has three modes. Each mode is described below.

### ● Local

Local is a mode in printing preparation state. All keys are available.

Receiving of data from the computer is allowed, however, printing is not executed.

The following operations are allowed in the local.

- (1) Setting an origin and the table height by pressing the JOG keys.
- (2) Executing "Test printing" by pressing the [FUNC2](TEST PRINT/CLEANING) key.
- (3) Executing "head cleaning" by pressing the [FUNC2](TEST PRING/CLEANING) key.
- (4) Execute setting of each function by pressing the [FUNC1](MENU) key.

### ● Menu Mode

Press the [FUNC1](MENU) key during the Local Mode to call the Function Mode.

Function settings on printing method can be set.

### ● Remote

Remote is a mode in printing received data.

Pressing of the [FUNC3](REMOTE) key suspends the machine.

Press the [FUNC3](REMOTE) during the Local Mode to switch to the Remote.

# Chapter 2

## Basic Operations



### This chapter

describes procedures and setting methods for ink and media preparation, and printing.

Operation flow .....	2-2	Printing an image from source data .....	2-8
Turning the Power ON/OFF .....	2-3	Starting the printing operation .....	2-8
Turning the Power ON .....	2-3	Interruption of printing .....	2-8
Turning the Power OFF .....	2-3	Checking printing data that is being received or has been received .....	2-9
Setting the media .....	2-4	When [! WORK High] is displayed .....	2-9
Set the media in another method .....	2-6	If you open the cover during printing .....	2-9
Test printing .....	2-6		
Execution of head cleaning .....	2-7		

## Operation flow

1

Turning the Power ON

See “Turning the Power ON” (🔗 P.2-3)

2

Setting the media

See “Setting the media” (🔗 P.2-4)

3

Test printing

See “Test printing” (🔗 P.2-6)

4

Execution of head cleaning

See “Execution of head cleaning” (🔗 P.2-7)

5

Printing an image from source data

See “Printing an image from source data” (🔗 P.2-8)

6

Turning the Power OFF

See “Turning the Power OFF” (🔗 P.2-3)



# Turning the Power ON/OFF

## Turning the Power ON

This machine is provided with the following two power switches:

### Main power switch :

It is located on the side of this machine. Keep this switch ON all the time.

### [END/POWER] key :

Normally, use this key to turn the power ON/OFF.

The nozzle clogging prevention function periodically operates even with the [END/POWER] key turned OFF when the main power switch is turned ON.

### 1 Turn the main power switch ON.

- Set the main power switch located on the side of this machine to the "I" side.

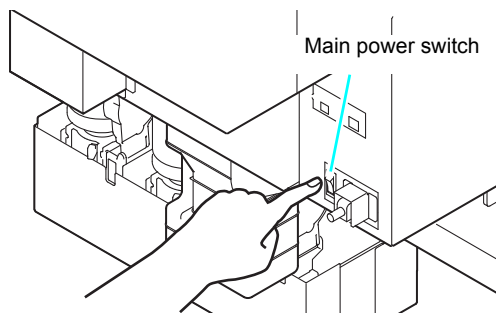

- The firmware version is displayed when the power is turned ON, and then the machine performs its initial operation.

### 2 Turn the power on, by pressing the [END/POWER] key.

- The machine enters LOCAL.

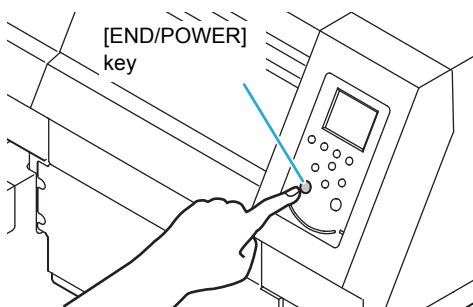

### 3 Turn ON the power of the connected PC.



- Turn the power ON after the front cover and maintenance cover are closed.
- The head nozzle may result in nozzle clogging if the main power switch is left OFF for a long time.

## Turning the Power OFF

When having ended the operation of the machine, turn the power OFF by pressing the power switch located on the front side.

Check the following items when turning the power OFF.

- If the machine is receiving data from the PC or if there is any data that has not been output yet
- If the head has returned to the capping station
- If any error has occurred  
(☞ P.5-6 "Error messages")

### 1 Turn OFF the power of the connected PC.

### 2 Turn the power off, by giving the [END/POWER] key a long press.

- Do not turn OFF the main power switch located on the side of the machine.
- To use this machine again, press the [END/POWER] key .

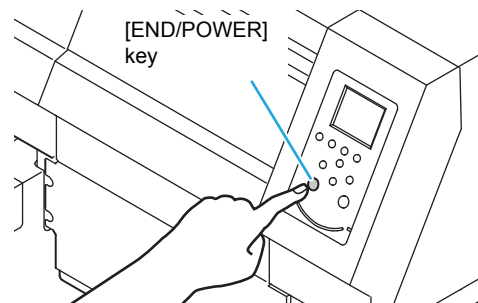

## Cautions about Turning the Power OFF

### ● Do not turn the main power switch OFF.

When the main power switch is ON, the power periodically turns ON and the nozzle clogging prevention function (flushing function) operates. When the main power switch has been turned OFF, the auto maintenance functions, such as flushing, do not operate, and this may cause nozzle clogging.

### ● Keep the front cover and the maintenance cover closed.

If the cover is opened, the auto maintenance function such as the flushing function does not work.

### ● Turn the power OFF after having checked the position of the head.

If the power is turned OFF in a state where the head has not returned to the capping station, the ink head dries, which may cause nozzle clogging. In this case, turn the power ON again and check that the head has returned to the capping station, and then turn the power OFF.

### ● Do not turn the power OFF during printing.

The head may not return to the capping station.

### ● After having turned the power switch OFF by pressing [END/POWER] key, turn the main power switch OFF.

When turning the main power switch off for moving the machine or for solving the error or the like, press the [END/POWER] key a long time on the front of the machine, check the display is turned off on the operation panel, and then turn the main power switch off.

## Setting the media



- The peripheral parts of the media could roll up due to heat. Fix the media supplementarily using adhesive tapes, etc.

### 1

#### Setting the media thickness.

- (1) Press the [FUNC1] (MENU) ➔ [▼] (1 time) ➔ [ENTER] key in LOCAL.
- (2) Select "MEDIA THICKNESS", and press the [ENTER] key.
- (3) Press [▲][▼] to set the media thickness, and press the [ENTER] key.



- When using a jig, enter the jig's height + the media thickness.

## Setting the Table Height

If the table height is changed, Media Thickness is also changed.

- 1 Press the **FUNC1 (MENU)** → **ENTER** key in LOCAL.
  - HEAD HEIGHT MENU will be displayed.
- 2 Press **▲** **▼** to select "TABLE HEIGHT", and press the **ENTER** key.
- 3 Press **▲** **▼** to set the table height, and press the **ENTER** key.
  - Set value : 0.0 to 153.0mm
- 4 Press the **END/POWER** key several times to end the setting.

## Changing origin

The default origin position can be changed by pressing JOG keys **▲****▼****◀****▶**.



- The origin can also be changed from "ORIGIN SETUP MENU". (P.3-4)

### Changing with the JOG keys

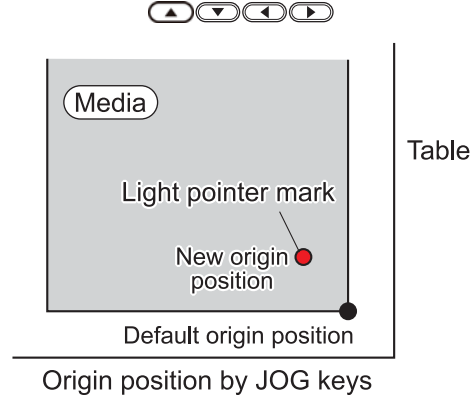

- 1 Press the **▲** **▼** **◀** **▶** keys in the local mode.
  - The origin setting mode starts
  - A red light pointer mark [●] is projected on the table or the media.
- 2 Move the light pointer mark by pressing the **▲** **▼** **◀** **▶** keys.

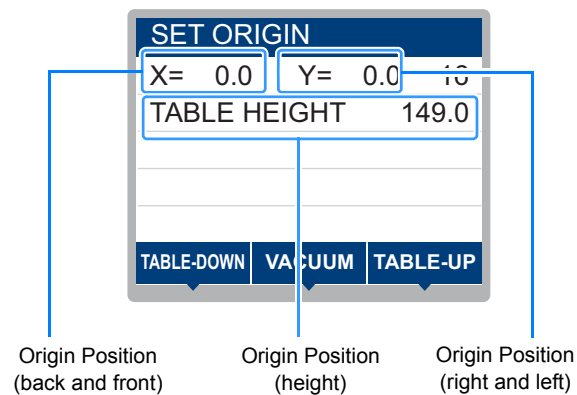

- Move the light pointer mark to the position to set a new origin.

- 3 Press the **ENTER** key when the printing origin is determined.

- The origin is changed.



- The height of the table is also fixed at the same time. Adjust the height of the table by pressing the TABLE **▲****▼** keys in advance.
- The setting value for the origin set with the JOG keys is cleared by cutting the power.
- The setting of the table height holds even if turning off the power.

## Set the media in another method

You can lower the table to set media more easily.

**1** Press the **FUNC1** (MENU) → **ENTER** key in LOCAL.

- The table moves down.

**2** Set media along the L-shaped mark (print origin) on the right corner of the table.

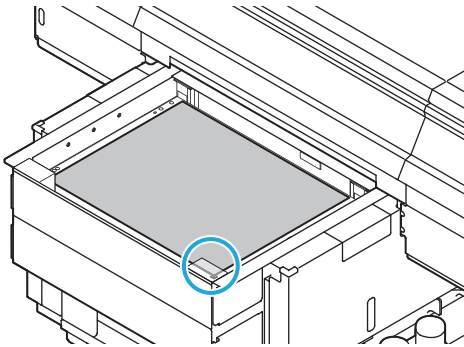

- To change the printing origin, see the following page. (P.2-5 “Changing origin”)
- To use tools, set into the shaves (8.0 mm-deep) on the corners of the table.

**3** Press the **ENTER** key.

- The table moves up to the table height for drawing.

## About switching vacuum fan

The vacuum function to fix the media at printing automatically starts.



- You can set the vacuum function operation. For details, refer to P.3-10 “Setting of FAN MODE.”
- When you set the “Fan mode” of the setting mode to “Manual”, switch ON/OFF by pressing the [VAC-UUM] key”.

## Test printing

Make test printing in the specified direction to check whether there is nozzle clogging or other printing failures (such as wearing or missing).



- When you use white or clear ink, print on the clear film to check.

### Check before starting test printing

• Is media set? ( P.2-4)	• Is origin point set? ( P.2-2)
• Is the table height appropriate? ( P.2-5)	

**1** Press the **FUNC2** (TEST PRINT/CLEANING) in the local.

**2** Press **▲** **▼** to select the printing direction, and press the **ENTER** key.

- When nozzle recovery is not set, test printing is started in the selected direction.
- SCAN DIR: Draws in the scan (widthwise) direction of the media.  
FEED DIR: Draws in the feed (longwise) direction of the media.



- When nozzle recovery is set, press **▲**/**▼** to set ON/ OFF and then press the **ENTER** key.  
ON : Draws with nozzle recovery ON.  
OFF : Draws with nozzle recover OFF.

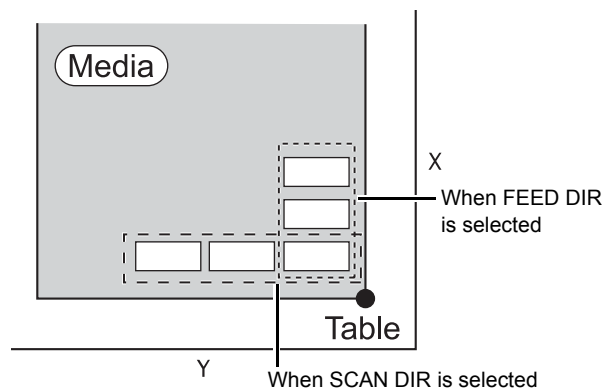

**3** Test printing ends.

- The table moves to the front side, and then the mode returns to the local.

## 4 Check result of printing.

- When the result is normal, finish the operation. (P.2-8)
- When the result is abnormal, execute head cleaning. (P.2-12)

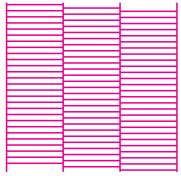
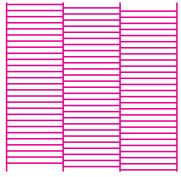
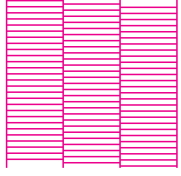
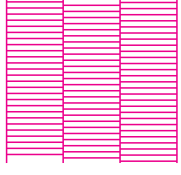
	Normal pattern
	
	Abnormal patterns
Nozzle drop out	 <p>Many lines are missing.</p>
Nozzle missing	 <p>The lines are missing as if the teeth are lost.</p>
Deflection	 <p>The distance between the lines is narrowing or double lines are formed.</p>

## Execution of head cleaning

When a correct pattern is not obtained in the test printing, perform the head-cleaning. As for the head cleaning, the following 3 types are available.

normal	To be used if ten odd numbers of the lines are missing when the test pattern is made. Suction and wiping will be performed.
hard	To be used when the missing of the lines does not improve with the "normal" cleaning.
soft	To be used when the lines are curved.

**1** Press the **FUNC2** (TEST PRINT/CLEANING) in the local.

**2** Select the head, set execution/non-execution of cleaning, and press the **ENTER** key.

(1) Select the head with [**◀**][**▶**].

(2) Select execution/non-execution of the head cleaning with [**◀**][**▶**].

- Select execution of cleaning for every head.

**Execute Cleaning** : Head color being set is displayed.

**Not Execute Cleaning** : " - " is displayed.

**3** Press **▲** **▼** to select the cleaning type, and press the **ENTER** key.

**4** Press the **ENTER** key.

- Cleaning is started.

- When the cleaning is completed, a mode is returned to the local mode.

**5** Execute test printing and check the result of the test printing.

- Repeat cleaning and test printing until normal result is obtained.

# Printing an image from source data

## Starting the printing operation



- If the temperature of the head has not reached the predetermined value, a message is displayed. Printing is not allowed in such cases. When the display is disappeared, printing can be started.



- Data transmission is allowed even if errors are displayed. Printing is started after the display is disappeared.

### 1 Set the media. (☞ P.2-4)

- When you set the FAN MODE setting (☞ P.3-10) to "MANUAL", press [SEL] and [FUNC1] (REMOTE) depending on the use and vacuum the media.

### 2 Press the **[FUNC3] (REMOTE)** in local.

- The machine goes in the remote mode and data from the computer can be received.
- The table height (including the vacuum table and the table spacer) is displayed.

### 3 Transmit data to be drawn from the computer.

- Printing conditions are displayed.
- As for the data transmission method, see the instruction manual of the output software.

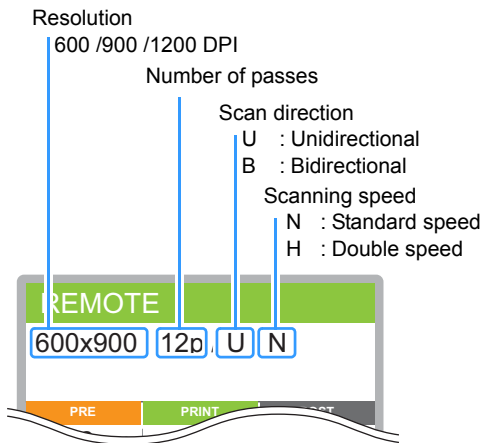

- This machine does not have "B" (bi-directional).

### 4 Start printing.

- The printing origin is not changed after completion of the printing.

### 5 Taking out the media after completion of printing.

- (1) When you made vacuum ON, Press the [FUNC1] (VACUUM) to turn the adsorption OFF.



- When you use the vacuum function of the vacuum table to draw, turn OFF the vacuum when printing has been completed.

- (2) Remove the media.



- During printing, media may be heated by the LED UV and raised, causing printing to be interrupted. In this case, set new media and restart printing.

## Interruption of printing

To interrupt printing, stop the printing operation and erase the received data from the machine.

### 1 Press **[FUNC3] (LOCAL)** while printing.

- Printing operation stops.
- When data is transmitted from the computer, the computer stops transmission of data.



- To restart printing, press the [FUNC3] (REMOTE).

### 2 Press the **[SEL]** key once.

- "DATA CLEAR" appears on the lower line of the display.

### 3 Press **[FUNC3] (DATACLEAR)**.

### 4 Press the **[ENTER]** key.

- Received data is erased and the machine returns to the local mode. Y-bar moves to the evacuation position.

## Checking printing data that is being received or has been received

When printing is interrupted or print data is received on the local mode, the warning message "DATA REMAIN" appears on the display.

At this time, if you press the [FUNC3] (REMOTE) to migrate to the remote, printing is started or restarted.



- Although another warning or error message appears on the second line of the display, if "DT" appears on the upper right, it means that the machine is in the "DATA REMAIN" status.

## When [! WORK High] is displayed

When warning message "! WORK High" is displayed on the screen and the printing operation stops during printing, restart printing with the procedures below:



- During printing, the sensor always monitors the media height. When the gap check function (P.3-3) is set to "OFF", if the sensor detects the media, the printing operation is interrupted automatically, and "! WORK High" is displayed on the screen.

### 1

Press the **ENTER** key.

- The screen returns to LOCAL.

### 2

Check the media setting status, and press the **FUNC3** (REMOTE).

- The machine restarts printing.
- If you do not wish to restart printing, refer to the P.2-8 "Interruption of printing" and interrupt printing.

## If you open the cover during printing

If you open the cover during printing, the warning message "Reset a switch" is displayed on the screen.

### 1

Close the cover and press the **ENTER** key to suspend printing.

- Machine starts initialization.



- If the cover is opened while printing is not performed, "Close the cover." is shown on the display. In this case, press the [ENTER] key





# Chapter 3

## Setup



### This chapter

describes the various setting of this machine.

About Head Height MENU .....	3-2	About MACHINE SETUP MENU .....	3-13
Head Height MENU table .....	3-2	MACHINE SETUP MENU table .....	3-14
Setting the Media Thickness .....	3-3	Setting Time .....	3-15
Setting the HEAD GAP .....	3-3	Setting Unit (Temperature/ Length) .....	3-15
Gap check .....	3-3	Setting a KEY BUZZER .....	3-15
About ORIGIN SETUP MENU .....	3-4	Set the network .....	3-16
ORIGIN SETUP MENU table .....	3-4	Setting event mail function .....	3-17
Setting the X offset .....	3-5	Setting a LANGUAGE .....	3-21
Setting the Y offset .....	3-5	Initializing the Settings .....	3-21
Setting the Z origin .....	3-5	About NOZZLE CHECK MENU .....	3-22
Changing the origin using the JOG keys .....	3-5	INFORMATION MENU table .....	3-22
About SETUP MENU .....	3-6	Printing Check Flow .....	3-23
SETUP MENU table .....	3-7	Printing Operations at "Nozzle Missing"	
Setting of Media Correction .....	3-8	Judgment and Error Occurrence .....	3-23
Setting of LOGICAL SEEK .....	3-8	Setting the Printing Check .....	3-24
Setting of INK LAYERS .....	3-9	Setting the NOZZLE RECOVERY .....	3-24
Setting of REFRESH LEVEL .....	3-9	Setting the Judgement Condition .....	3-24
Setting of PRIORITY .....	3-9	About INFORMATION MENU .....	3-25
Setting of UV MODE .....	3-10	INFORMATION MENU table .....	3-25
Setting of WORK CHANGE .....	3-10	Displaying the Information .....	3-26
Setting of FAN MODE .....	3-10		
Setting of AUTO CLEANING .....	3-10		
Setting of PRINT FLUSHING LEVEL .....	3-11		
Setting of MAPS .....	3-11		
Setting of the Misregistration adjust .....	3-12		

# About Head Height MENU

On SETUP MENU, you can set the print conditions to match the media you usually use.

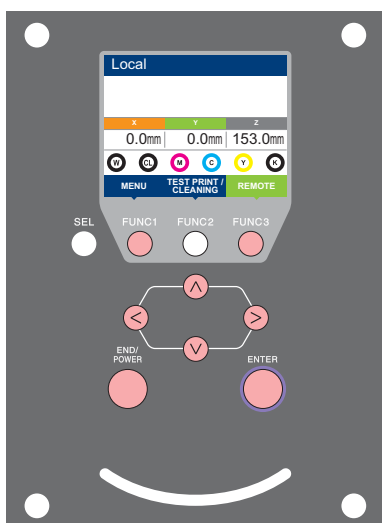

- FUNC1** : Press this to select SETUP MENU, or to switch to the previous screen.
- ▲ ▼** : Press this to switch to the next screen.
- ENTER** : Use these to select a setting item.
- ◀ ▶** : Press this to confirm a setting, etc..

## ◆ SETUP MENUs at-a-glance

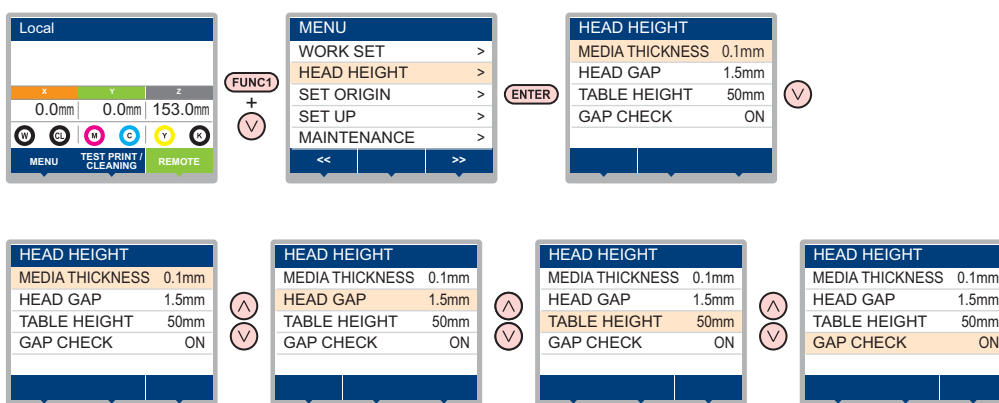

## Head Height MENU table

Function name	Set value*1	Outline
MEDIA THICKNESS ( P.3-3)	0.0 to 153.0mm	Setting the thickness of media.
HEAD GAP ( P.3-3)	1.5 to 5.0mm	Setting the head gap.
TABLE HEIGHT ( P.2-5)	0.0 to 153.0mm	Setting the height of the vacuum table.
GAP CHECK ( P.3-3)	ON/ OFF	Selecting an operation when obstacles are detected during printing.

\*1. The underlined value is set at the time of purchase.

## Setting the Media Thickness

If the media thickness is changed, Table Height is also changed.

- 1 Press the **FUNC1 (MENU)** → **▼** → **ENTER** key in LOCAL.
  - HEAD HEIGHT MENU will be displayed.
- 2 Press **▲** **▼** to select “MEDIA THICKNESS”, and press the **ENTER** key.
- 3 Press **▲** **▼** to set the media thickness, and press the **ENTER** key.
  - Set value : 0.0 to 153mm
- 4 Press the **END/POWER** key several times to end the setting.

## Setting the HEAD GAP

If the head gap is changed, Table Height is also changed.

- 1 Press the **FUNC1 (MENU)** → **▼** → **ENTER** key in LOCAL.
  - HEAD HEIGHT MENU will be displayed.
- 2 Press **▲** **▼** to select “HEAD GAP” **ENTER** key.
- 3 Press **▲** **▼** to set the table spacer, and press the **ENTER** key.
  - Setting value : 1.5 to 5.0 mm
- 4 Press the **END/POWER** key several times to end the setting.

## Gap check

Select operation when obstacles are detected during printing.

- 1 Press the **FUNC1 (MENU)** → **▼** → **ENTER** key in LOCAL.
  - HEAD HEIGHT MENU will be displayed.
- 2 Press **▲** **▼** to select “GAP CHECK”, and press the **ENTER** key.
- 3 Press **▲** **▼** to select the mode, and press the **ENTER** key.
  - Set value: ON, OFF
  - When ON is selected:
    - Before drawing, the work height is checked with the specified table height (media thickness).
    - Before and during drawing, if the work sensor is shielded, the table is lowered until it is unshielded to change the table height.
    - If the work sensor is shielded when the table is lowered to the bottom, a message of [WORK High] appears and the operation stops.
  - When OFF is selected:
    - Before drawing, the work height is checked with the specified table height (media thickness), and if the work sensor is shielded, a message of [WORK High] appears and the operation stops.
- 4 Press the **END/POWER** key several times to end the setting.

**Important!**

- The gap check function is not a function to avoid the head hit completely by detecting obstacles. Even when the GAP CHECK is “ON”, be sure to check the work height visually before drawing.

# About ORIGIN SETUP MENU

Common settings are functions for using this machine easily.  
The following items can be set in Origin settings.

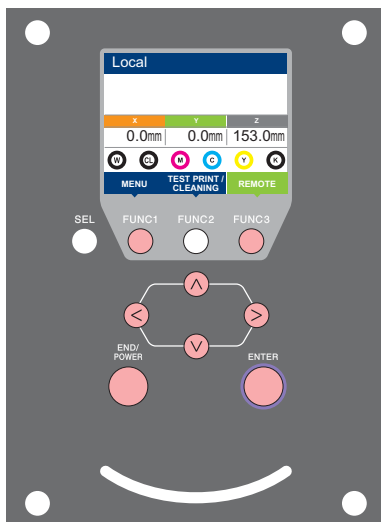

- FUNC1** : Press this to select SETUP MENU, or to switch to the previous screen.
- ▲ ▼** : Press this to switch to the next screen.
- ENTER** : Use these to select a setting item.
- ◀ ▶** : Press this to confirm a setting, etc..

## ◆ SETUP MENUs at-a-glance

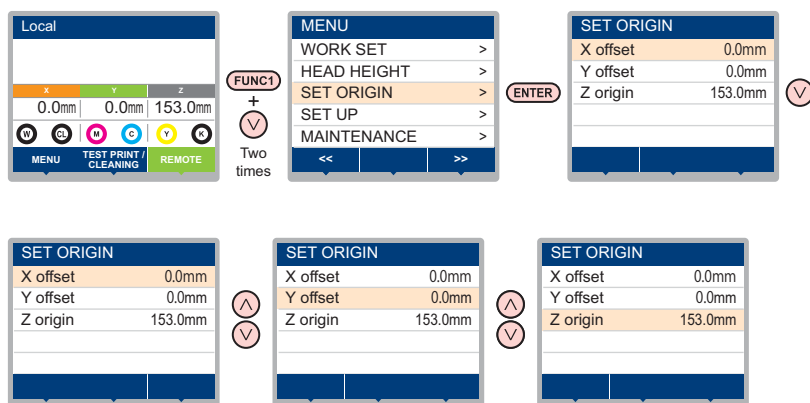

## ORIGIN SETUP MENU table

Function name	Set value	Outline
X offset (🔧 P.3-5)	0.0mm~510.0mm	Setting the origin position of X-axis. (offset value)
Y offset (🔧 P.3-5)	0.0mm~712.0mm	Setting the origin position of Y-axis. (offset value)
Z origin (🔧 P.3-5)	0.0mm~153.0mm	Setting the Z origin (table height).

## Setting the X offset

Use the following steps to correctly set the X origin. The origin you set here indicates the position of the X origin = 0.

- 1 Press the **FUNC1** (MENU)  $\rightarrow$  **▼** (twice)  $\rightarrow$  **ENTER** key in LOCAL.
  - ORIGIN SETUP MENU will be displayed.
- 2 Press **▲▼** to select "X OFFSET", and press the **ENTER** key.
- 3 Press **▲▼** to set the X-axis origin position, and press the **ENTER** key.
  - The value in the parentheses indicates the distance from the origin to the maximum effective area.
- 4 Press the **END/POWER** key several times to end the setting.

## Setting the Y offset

Use the following steps to correctly set the X origin. The origin you set here indicates the position of the X origin = 0.

- 1 Press the **FUNC1** (MENU)  $\rightarrow$  **▼** (twice)  $\rightarrow$  **ENTER** key in LOCAL.
  - ORIGIN SETUP MENU will be displayed.
- 2 Press **▲▼** to select "Y OFFSET", and press the **ENTER** key.
- 3 Press **▲▼** to set the Y-axis origin position, and press the **ENTER** key.
  - The value in the parentheses indicates the distance from the origin to the maximum effective area.
- 4 Press the **END/POWER** key several times to end the setting.

## Setting the Z origin

- 1 Press the **FUNC1** (MENU)  $\rightarrow$  **▼** (twice)  $\rightarrow$  **ENTER** key in LOCAL.
  - ORIGIN SETUP MENU will be displayed.
- 2 Press **▲▼** to select "Z ORIGIN", and press the **ENTER** key.
- 3 Press **▲▼** to set the origin position of Z-axis, and press the **ENTER** key.

- 4 Press the **END/POWER** key several times to end the setting.

Changing with the "ORIGIN" in the FUNCTION menu

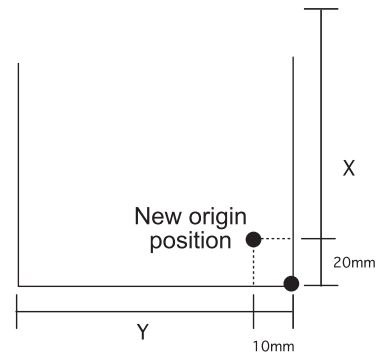

## Changing the origin using the JOG

You can also change the origin using the JOG keys.

Changing with the JOG keys

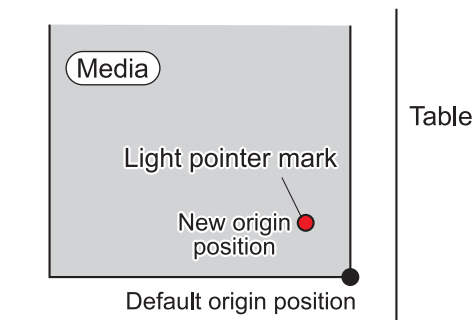

Origin position by JOG keys

- 1 Press **▲▼◀▶** keys in local.
  - The origin setting mode starts
  - A red light pointer mark [●] is projected on the table or the media.
- 2 Press **▲▼◀▶** to move the light pointer mark
  - Move the light pointer mark to the position to set a new origin.
- 3 Press the **ENTER** key to set the print origin.
  - The origin is changed.

**Important!**

- The height of the table is also fixed at the same time. Adjust the height of the table by pressing the [TABLE-UP][TABLE-DOWN] keys in advance.
- The setting value for the origin set with the JOG keys is cleared by cutting the power.
- The setting of the table height holds even if turning off the power.

# About SETUP MENU

On SETUP MENU, you can set the print conditions to match the media you usually use.

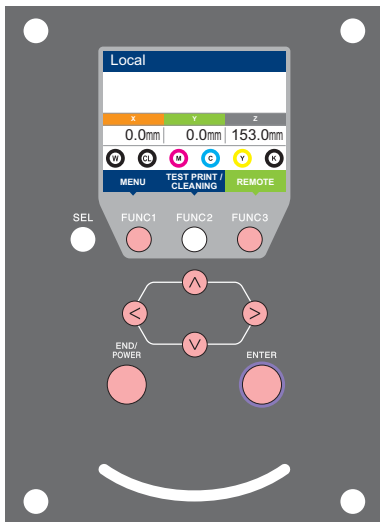

- FUNC1** : Press this to select SETUP MENU, or to switch to the previous screen.
- FUNC3** : Press this to switch to the next screen.
- ▲ ▼** : Use these to select a setting item.
- ENTER** : Press this to confirm a setting, etc..

## ◆ SETUP MENUs at-a-glance

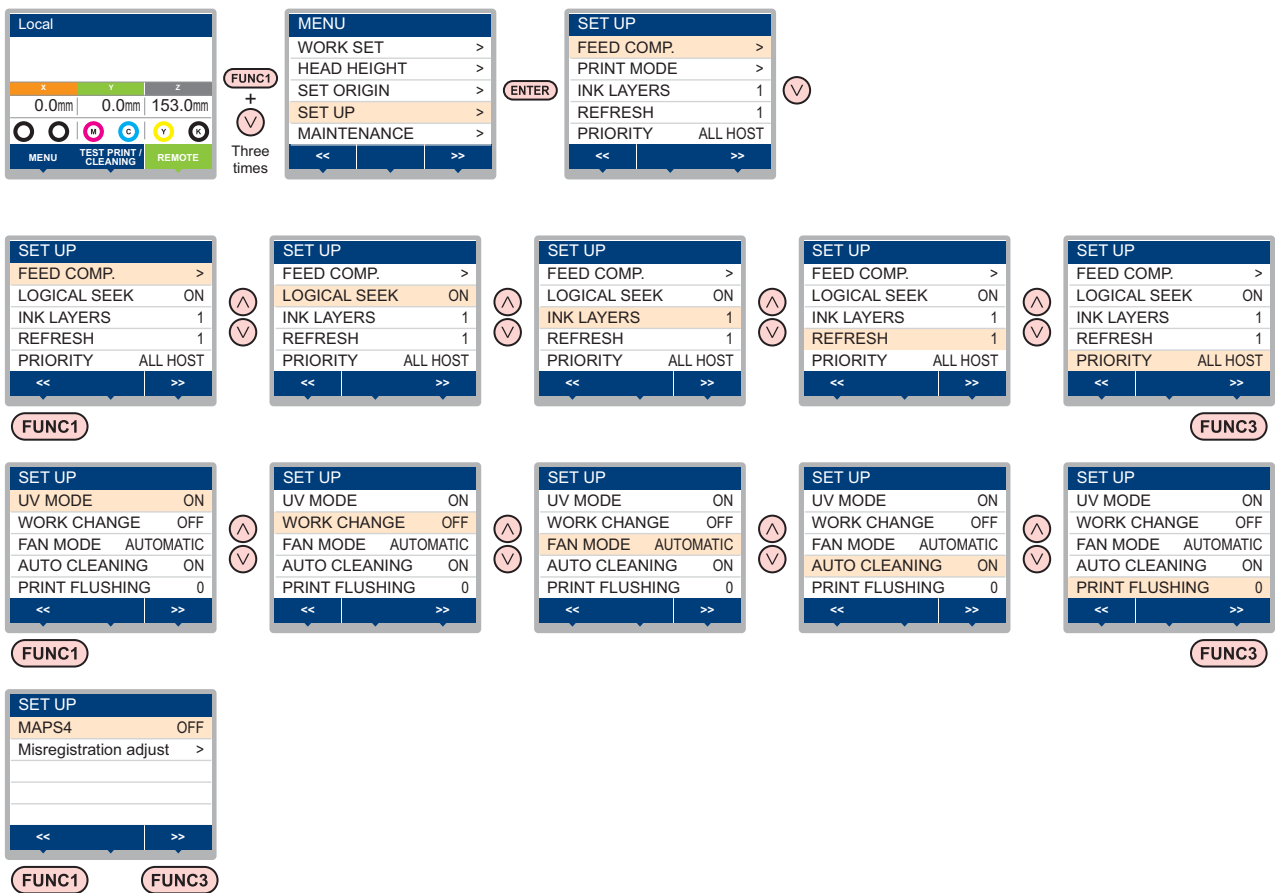

## SETUP MENU table



- For each setting item below, you can set it so that the machine may operate according to the value specified when you printed from your RIP software in the connected host PC.
- **Set Item** : FEED COMP./INK LAYER/Logical Seek/REFRESH
- When you operate the machine according to the contents specified with the RIP software, set each item to "Host" when registering this machine type. When you set it other than "Host", the machine operates according to the machine setting.
- For the specifying method with the RIP software, refer to the operation manual of the RIP software.

Function name	Set value *1	Outline
FEED COMP. (☞ P.3-10)	-9999 ~ <u>0</u> ~ 9999	Used to print a pattern for correcting a media-feeding rate and correct it.
LOGICAL SEEK (☞ P.3-8)	ON / OFF	Sets the scan movable area during printing.
INK LAYERS (☞ P.3-9)	1 ~ 9	Sets the number of layers in which ink is to be applied.
REFRESH LEVEL (☞ P.3-9)	0 ~ 3	Sets the interval of refresh performed during printing.
PRIORITY (☞ P.3-9)	ALL HOST/ALL PLOT/ INDIVIDUAL	Selects the priority from the settings on this machine (PLOT) or the settings on a computer (HOST) about the following items. Items: FEED COMP./INK LAYER/Logical Seek/REFRESH
UV MODE (☞ P.3-10)	ON/OFF/NO PRINT	Sets the UV irradiation during printing.
WORK CHANGE (☞ P.3-10)	ON / OFF	Set whether to return to the local mode or keep the remote mode after online drawing.
FAN MODE (☞ P.3-10)	AUTOMATIC/MANUAL	Sets the vacuum function.
AUTO CLEANING (☞ P.3-10)	ON / OFF	Sets the automatic cleaning operation for the head performed before printing.
PRINT FLUSHING LEVEL (☞ P.3-11)	0 ~ 3	Sets the flushing amount before printing.
MAPS4 (☞ P.3-11)	MANUAL, AUTO	Perform setting to reduce stripes between passes.
Misregistration adjust (☞ P.3-12)	-8 ~ <u>0</u> ~ 8	Correct the mis-registration occurs at printing the color/spot color version.

\*1. The underlined value is set at the time of purchase.

## Setting of Media Correction

A pattern for media correction is printed and a feeding rate is corrected.



- Three bands are printed in the correction pattern.
- Make adjustment so that an even color density is obtained in the boundary between the three bands.

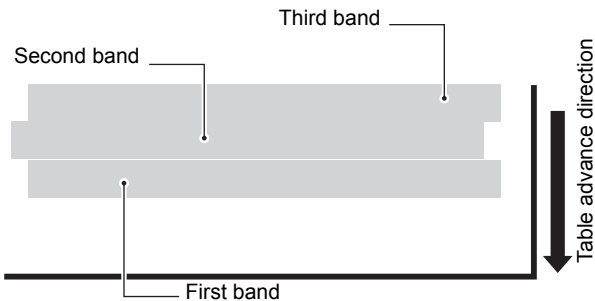

**1** Set a media. (☞ P.2-4)

**2** Press the **FUNC1** (MENU) → (3 times) → **ENTER** key in LOCAL.

- SETUP MENU will be displayed.

**3** Press ▲ ▼ to select "FEED COMP.", and press the **ENTER** key.

**4** Press **ENTER** the key to print a correction pattern.

**5** Check the correction pattern and enter a correction value.

- A screen for entering the correction value will be displayed.
- **Enter a correction value in "+":**  
The boundary between the two bands is widened.
- **Enter a correction value in "-":**  
The boundary between the two bands is narrowed.
- When you change the correction value by "1", the width of the boundary changes by about 0.83μm.

**6** Press the **ENTER** key.

- Print a correction pattern again and check it.
- When media correction is needed, perform the operation in Step 5 to make correction.

**7** Press the **END/POWER** key several times to end the setting.

## Setting of LOGICAL SEEK

The head's operation varies depending on the LOGICAL SEEK settings, as shown in the figure below.

**Movement of heads when LOGICAL seek is OFF**

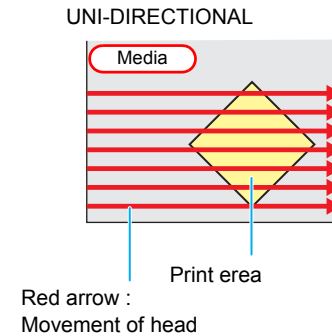

**Movement of heads when LOGICAL seek is ON**

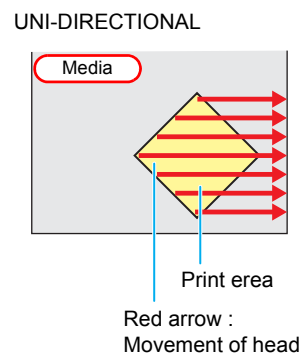

**1** Press the **FUNC1** (MENU) → (3 times) → **ENTER** key in LOCAL.

- SETUP MENU will be displayed.key.

**2** Press ▲ ▼ to select "LOGICAL SEEK", and press the **ENTER** key.

**3** Press ▲ ▼ to select a set value, and press the **ENTER** key.

- Set value : ON / OFF

**4** Press the **END/POWER** key several times to end the setting.



## Setting of INK LAYERS

Set the number of times for over painting.  
Finer drawing can be obtained by over painting.

- 1 Press the **FUNC1 (MENU)** (3 times) → **ENTER** key in LOCAL.
  - SETUP MENU will be displayed.
- 2 Press **▲▼** to select "INK LAYERS", and press the **ENTER** key.
- 3 Press **▲▼** to select a set value, and press the **ENTER** key.
  - Set value : 1 to 9 times
- 4 Press the **END/POWER** key several times to end the setting.

**Important!** • To perform over painting, be sure to set "PLOT" for INK LAYER in PRIORITY.

## Setting of REFRESH LEVEL

Set the refreshing level for preventing the head from clogging in a dusty environment.  
The larger level number indicates more frequent refreshing times.

- 1 Press the **FUNC1 (MENU)** (3 times) → **ENTER** key in LOCAL.
  - SETUP MENU will be displayed.
- 2 Press **▲▼** to select "REFRESH", and press the **ENTER** key.
- 3 Press **▲▼** to select a set value, and press the **ENTER** key.
  - Set value : Level 1 to 3
- 4 Press the **END/POWER** key several times to end the setting.

## Setting of PRIORITY

Select priority of setting of this machine or that of the computer on the following items respectively.

Item : FEED COMP/INK LAYERS/LOGICAL SEEK/REFRESH

- Important!** • When you give priority to the setting at the RIP software side, make the setting value "Host".
- 1 Press the **FUNC1 (MENU)** (3 times) → **ENTER** key in LOCAL.
    - SETUP MENU will be displayed.
  - 2 Press **▲▼** to select "PRIORITY", and press the **ENTER** key.
  - 3 Press **▲▼** to select a set value, and press the **ENTER** key.
    - Set value : ALL HOST/ALL PLOT/INDIVIDUAL
    - If you select [INDIVIDUAL], proceed to Step 4. If you select other items, proceed to Step 6.
  - 4 Press **▲▼** to select a set value, and press the **ENTER** key.
  - 5 Press the **END/POWER** key several times to end the setting.

## Setting of UV MODE

The mode of the LED UV may be set in 3 stages. This setting is made when the media vulnerable to the heat is used or when the test drawing is made in which the lighting of the LED UV is not desired.

ON	The LED UV is lit.
OFF	The LED UV is not lit.
NO PRINT	The drawing is not performed and only the LED UV is lit. Use when drawing is performed without the LED UV is lit etc., and when you wish to make it cure afterward.

- 1** Press the **FUNC1 (MENU)**  $\rightarrow$  **▼** (3 times)  $\rightarrow$  **ENTER** key in LOCAL.
  - SETUP MENU will be displayed.
- 2** Press the **FUNC3 (>>)**.
- 3** Press **▲ ▼** to select "UV MODE", and press the **ENTER** key.
- 4** Press the **ENTER** key.
- 5** Press **▲ ▼** to select a set value, and press the **ENTER** key.
  - Set value : ON/OFF/NO PRINT
- 6** Press the **END/POWER** key several times to end the setting.

## Setting of WORK CHANGE

When you use the vacuum table, you can set whether the vacuum function to fix the media set on the vacuum table is performed automatically or you perform it manually.

- 1** Press the **FUNC1 (MENU)**  $\rightarrow$  **▼** (3 times)  $\rightarrow$  **ENTER** key in LOCAL.
  - SETUP MENU will be displayed.
- 2** Press the **FUNC3 (>>)**.
- 3** Press **▲ ▼** to select "WORK CHANGE", and press the **ENTER** key.
- 4** Press **▲ ▼** to select a set value, and press the **ENTER** key.
  - Set value : ON/ OFF
- 5** Press the **END/POWER** key several times to end the setting.

## Setting of FAN MODE

You can set whether the vacuum function to fix the media set on the table is performed automatically or you perform it manually.

The factory default is "AUTOMATIC".

- 1** Press the **FUNC1 (MENU)**  $\rightarrow$  **▼** (3 times)  $\rightarrow$  **ENTER** key in LOCAL.
  - SETUP MENU will be displayed.
- 2** Press the **FUNC3 (>>)**.
- 3** Press **▲ ▼** to select "FAN MODE", and press the **ENTER** key.
- 4** Press **▲ ▼** to select a set value, and press the **ENTER** key.
  - Set value : AUTOMATIC/ MANUAL
- 5** Press the **END/POWER** key several times to end the setting.

## Setting of AUTO CLEANING

Set whether auto-head cleaning is executed or not at the following intervals before drawing.

- 1** Press the **FUNC1 (MENU)**  $\rightarrow$  **▼** (3 times)  $\rightarrow$  **ENTER** key in LOCAL.
  - SETUP MENU will be displayed.
- 2** Press the **FUNC3 (>>)**.
- 3** Press **▲ ▼** to select "AUTO CLEANING", and press the **ENTER** key.
- 4** Press **▲ ▼** to select a set value, and press the **ENTER** key.
  - Set value : ON/ OFF
- 5** Press the **END/POWER** key several times to end the setting.

## Setting of PRINT FLUSHING LEVEL

When using a clear acrylic jig and so on, the ink may splash on the print result as the ink on the nozzles thickens due to stray light.

If this happens, increase the flushing amount before printing to prevent ink from splashing.

**1** Press the **FUNC1** (MENU)  $\rightarrow$  **▼** (3 times)  $\rightarrow$  **ENTER** key in LOCAL.

- SETUP MENU will be displayed.

**2** Press the **FUNC1** (<<).

**3** Press **▲▼** to select "PRINT FLUSHING", and press the **ENTER** key.

**4** Press **▲▼** to select a set value, and press the **ENTER** key.

- Set value : Level 0 to 3

**Important!**

- If you are using the printer in an environment subject to stray light, select level 2. Level 2 uses the same flushing amount as cleaning.  
If the same error still occurs, change the setting to level 3.  
If you can print without problem in level 2 and you are concerned about the amount of ink consumed, change the setting to level 1.
- For the amount of ink consumed for each level, see the following.
 

Level 0	: 0.03 cc
Level 1	: 0.06 cc
Level 2	: 0.12 cc
Level 3	: 0.18 cc

**5** Press the **END/POWER** key several times to end the setting.

## Setting of MAPS

If performing media correction does not resolve feeding stripes, use the MAPS (Mimaki Advanced PassSystem) function to disperse the pass boundary to make the feeding stripes less visible.

**1** Press the **FUNC1** (MENU)  $\rightarrow$  **▼** (3 times)  $\rightarrow$  **ENTER** key in LOCAL.

- SETUP MENU will be displayed.

**2** Press the **FUNC1** (<<).

**3** Press **▲▼** to select "MAPS4", and press the **ENTER** key.

**4** Press **▲▼** to set "AUTO" or "MANUAL".

**AUTO** : Set the print pattern and smoothing level to the recommended value automatically depending on printing mode.

**MANUAL** : You can adjust the set value.

**Important!**

- If feeding stripes and color change is not improved by "AUTO" setting, please adjust the print pattern and smoothing level by "MANUAL" setting.

**5** Press the **ENTER** key.

- If you select AUTO in Step 5, return to Step 3.
- If you select MANUAL in Step 4, proceed to Step 6.

**6** Set the smoothing for the color ink.

(1) Press the **▲▼** keys to select smoothing level.

- 0~100% : The MAPS effect become strong as the set value increase, and become weak as the set value decrease. (set in units of 5%)

(2) Press the **ENTER** key.

- Set the color ink smoothing level and proceed to Step 7.

(3) Press the **◀▶** key.

- Set the color ink smoothing level and proceed to Step 10.

**7** Set the smoothing for the spot color ink.

(1) Press the **▲▼** keys to select smoothing level.

- 0~100% : The MAPS effect become strong as the set value increase, and become weak as the set value decrease. (set in units of 5%)

(2) Press the **ENTER** key.

- Set the spot color ink smoothing level and proceed to Step 9.

(3) Press the **◀▶** key.

- Set the spot color ink smoothing level and proceed to Step 8.

**8** Press the **END/POWER** key several times to end the setting.

### Setting of the Misregistration adjust

It is used when the mis-registration occurs at printing the color/spot color version.

- 1** Press the **FUNC1** (MENU)  $\rightarrow$  **▼** (3 times)  $\rightarrow$  **ENTER** key in LOCAL.
  - SETUP MENU will be displayed.
- 2** Press the **FUNC1** (<<).
- 3** Press **▲▼** to select “Misregistration adjust”, and press the **ENTER** key.
- 4** Press **▲▼** to choose “feed direction”, “scan direction” or “reverse print”.
  - Feed direction** : correct the mis-registration of feed direction
  - Scan direction** : correct the mis-registration of scan direction
  - Reverse print** : correct the mis-registration of feed direction in the forward print (color to spot color) and reverse print (spot color to color)
- 5** Press the **ENTER** key.
  - If you select the feed direction or scan direction in Step 4, proceed to Step 6.
  - If you select the reverse print in Step 4, enter the deviation amount of feed direction of forward print and reverse print in 0.01mm unit.(See figure below).

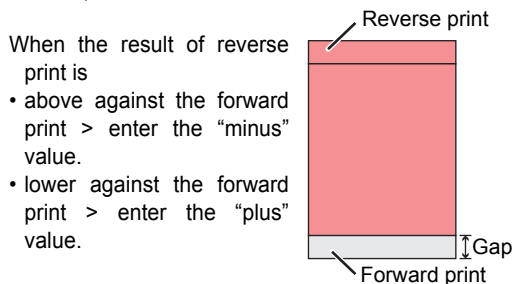

- 6** Press **▲▼** to select the resolution to adjust, and press the **ENTER** key.
  - Feed direction**: 600dpi/900dpi/1200dpi
  - Scan direction**: 600dpi/1200dpi
- 7** Press **▲▼** to select “Print” or “Set Adjust”, and press the **ENTER** key.
  - print**: print the adjustment pattern.
  - \*Use transparent media with the A4 landscape size or more in Y direction.
  - Set Adjust**: back to Step 6.
- 8** Print the adjustment pattern.
  - The straight line of the central pattern (correction value is 0) is a little longer than others both for the feed direction and scan direction.
- 9** Check the adjustment pattern (see figure below), and enter the adjustment value.
  - Input screen of the correction value is displayed.
  - Choose the number that two lines are overlapped to clean in the adjustment pattern and enter to the correction value.
  - In the case of the figure below, for the best pattern is “-2”, enter “-2” in correction value.
- 10** Press the **END/POWER** key several times to end the setting.

### Adjustment pattern

Feed direction

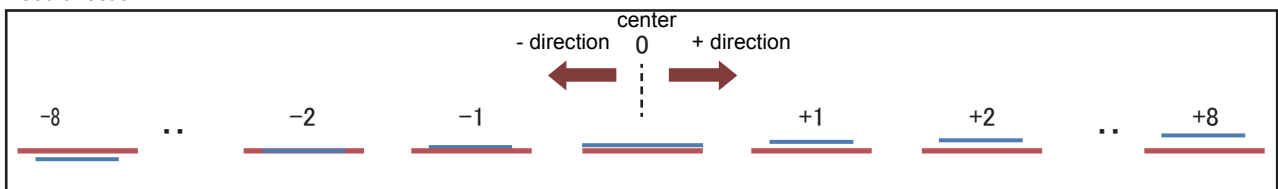

Scan direction

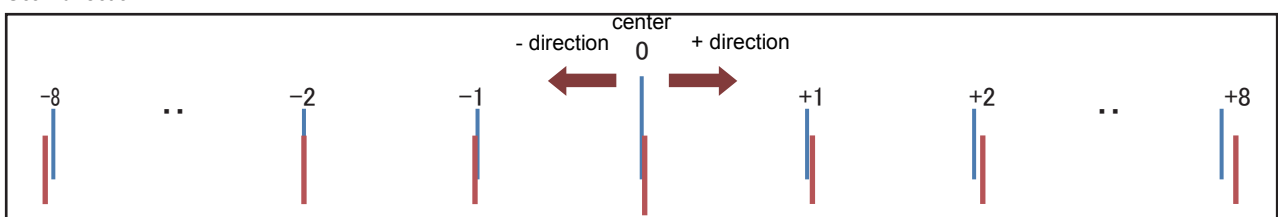

# About MACHINE SETUP MENU

Common settings are functions for using this machine easily.  
The following items can be set in Machine settings.

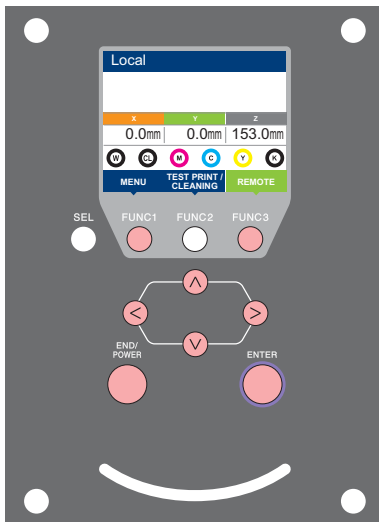

**FUNC1** : Press this to select SETUP MENU, or to switch to the previous screen.

**FUNC3** : Press this to switch to the next screen.

**▲ ▼** : Use these to select a setting item.

**ENTER** : Press this to confirm a setting, etc..

## ◆ SETUP MENUs at-a-glance

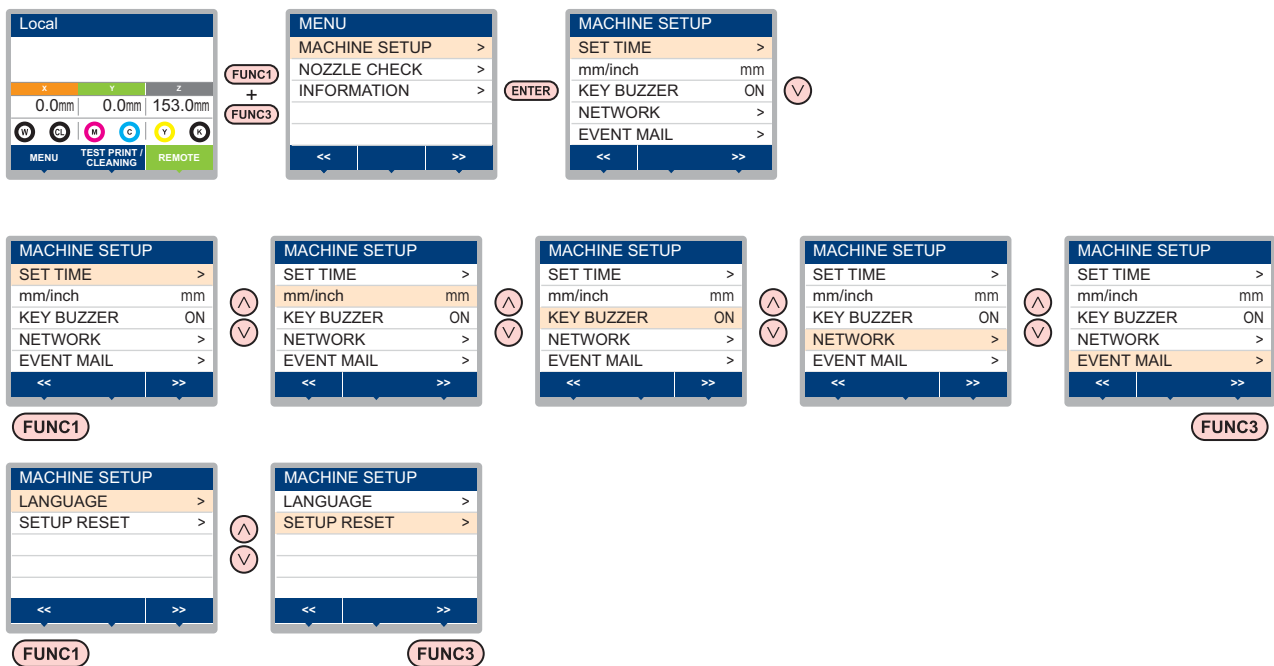

## MACHINE SETUP MENU table

Function name		Set value		Default	Meaning	
TIME (P.3-15)		+4h ~ -20h		Japan time	Time difference is corrected.	
mm/ inch (P.3-15)		mm / inch		°C	A unit for displaying length is set.	
KEY BUZZER (P.3-15)		OFF / ON		ON	A buzzer sound when keys are pressed is set.	
NETWORK (P.3-16)	Set the network.					
	Check IP Addr.	The IP address currently used by this machine is displayed.				
	Check MAC Addr.	The IP address currently used by this machine is displayed.				
	DHCP	ON / OFF			When it is ON, the IP address given by the DHCP server is used.	
	AutoIP	ON / OFF			When it is ON, the IP address is determined by the AutoIP protocol. However, DHCP is ON, DHCP has priority.	
	IP Address *1	Set the IP address used by this machine.				
	Default Gateway *1	Set the default gateway used by this machine.				
	DNS Address *1	Set the DNS server address used by this machine.				
	SubNet Mask *1	Set the digit number of the subnet mask used by this machine.				
EVENT MAIL	Mail Delivery (P.3-17)	ON / OFF		OFF	Set whether you send/ do not send the e-mail when the set event occurs.	
	Select Event (P.3-17)	Print Start Event	ON / OFF	OFF	Set whether you send/ do not send the e-mail at the start of printing.	
		Print End Event	ON / OFF	OFF	Set whether you send/ do not send the e-mail at the end of printing.	
		Error Event	ON / OFF	OFF	Set whether you send/ do not send the e-mail when a error occurs.	
		Warning Event	ON / OFF	OFF	Set whether you send/ do not send the e-mail when a warning occurs.	
		Other Event	ON / OFF	OFF	Set whether you send/ do not send the e-mail when an event other than the above occurs.	
	Mail Address (P.3-18)	Set the e-mail address to which you send the event mail.		Alphanumeric characters and symbols (within 96 characters)		
	Message Subject (P.3-18)	Set the characters to write in the subject of the event mail.		Alphanumeric characters and symbols (within 8 characters)		
	Server Setup (P.3-18)	SMTP Address		Set the SMTP server.		
		SMTP Port No.		Set the SMTP port number.		
		SENDER ADDRESS		Set the e-mail address to be used as the sender mail address.		
		Authentication	POP before SMTP	Set the SMTP server authentication method (SMTP authentication).		
			SMTP Authentication			
			OFF			
		User Name *2		Set the user name used for the authentication.		
Pass Word *2		Set the password used for the authentication.				
POP3 Address *3		Set the POP server.				
APOP *3		Set ON/ OFF of APOP.				
Transmit Test (P.3-19)	Send the test e-mail.					
LANGUAGE (P.3-21)		English / 日本語		English	Displayed language is changed.	
SETUP RESET (P.3-21)					All setting values are returned to the status default.	

\*1. Settable when both of DHCP and AutoIP are [OFF]

\*2. Settable only when Auth. is not OFF

\*3. Settable only when Auth. is POP before SMTP

## Setting Time

You can set time of your country (time difference).

- 1 Press the **FUNC1** (MENU) → **FUNC3** (>>) → **ENTER** key in LOCAL.
  - MACHINE SETUP MENU will be displayed.
- 2 Press **▲** **▼** to select "TIME", and press the **ENTER** key.
- 3 Press **▲** **▼** **◀** **▶** to enter time, and press the **ENTER** key.
  - Hour/Minute/Second/Time selecting: by the [**◀**][**▶**] keys.
  - Hour/Minute/Second/Time inputting: by the [**▲**][**▼**] keys.
- 4 Press the **END/POWER** key several times to end the setting.



- -20 hours to +4 hours can be set.

## Setting Unit (Temperature/ Length)

Units used by this machine are set.

- 1 Press the **FUNC1** (MENU) → **FUNC3** (>>) → **ENTER** key in LOCAL.
  - MACHINE SETUP MENU will be displayed.
- 2 Press **▲** **▼** to select a set value, and press the **ENTER** key.
  - Set value of length : mm / inch
- 3 Press the **END/POWER** key several times to end the setting.

## Setting a KEY BUZZER

You can turn off the buzzer sound when pressing the key.

- 1 Press the **FUNC1** (MENU) → **FUNC3** (>>) → **ENTER** key in LOCAL.
  - MACHINE SETUP MENU will be displayed.
- 2 Press **▲** **▼** to select "KEY BUZZER", and press the **ENTER** key.
- 3 Press **▲** **▼** to select a set value, and press the **ENTER** key.
  - Set value : ON/ OFF
- 4 Press the **END/POWER** key several times to end the setting.



- When the key buzzer is set to "OFF", the buzzer sound for errors, warnings, operation completion, etc. cannot be shut off.

## Set the network

You can also perform network setting with “Network Configurator”, the tool to perform network setting of Mimaki’s product. To download the Network Configurator, check “Driver / Utility” on the download page at Mimaki Engineering (<http://eng.mimaki.co.jp/download/>).

**1** Press the **FUNC1 (MENU)** → **FUNC3 (>>)** → **ENTER** key in LOCAL.

- MACHINE SETUP MENU will be displayed.

**2** Press **▲▼** to select “NETWORK”, and press the **ENTER** key.

**3** Press **▲▼** to select “CHECK IP ADDRESS”, and press the **ENTER** key.

- The IP address currently used by this machine is displayed.
- When you have finished the check, press the [ENTER] key.



- After connecting with the network, it takes time until the IP address is determined. If the IP address has not been determined, “0.0.0.0” is displayed.

**4** Press **▲▼** to select “CHECK MAC ADDRESS”, and press the **ENTER** key.

- The MAC address currently used by this machine is displayed.
- When you have finished the check, press the [ENTER] key.

**5** Press **▲▼** to select “DHCP”, and press the **ENTER** key.

**6** Press **▲▼** to select a set value, and press the **ENTER** key.

- Set value : ON/ OFF
- When it is ON, the IP address given by the DHCP server is used.

**7** Press **▲▼** to select “AutoIP”, and press the **ENTER** key.

**8** Press **▲▼** to select a set value, and press the **ENTER** key.

- Set value : ON/ OFF
- When it is ON, the IP address is determined by the AutoIP protocol. However, DHCP is ON, DHCP has priority.

**9** Press **▲▼** to select “IP ADDRESS”, and press the **ENTER** key.

**10** Press **▲▼** to select a set value, and press the **ENTER** key.

**11** Press the **END/POWER** key several times to end the setting.



- To reflect network setting, once turn off the power supply and turn it on again.



## Setting event mail function

Set the function to send e-mails to the set e-mail address when events such as cutting start/ end and stop due to an error.

You can also perform network setting with "Network Configurator", the tool to perform network setting of Mimaki's product. To download the Network Configurator, check "Driver / Utility" on the download page at Mimaki Engineering (<http://eng.mimaki.co.jp/download/>).

- Disclaimer
- The customer is responsible for the communication fee for Internet communication such as e-mail notification.
- The notification by the event mail function may not be delivered due to Internet environment, failure of the device/ the power supply, etc. Mimaki has absolutely no responsibility for any damages or loss resulting from non-delivery or delays.

- Important!**
- You can use event mail function by connecting LAN to this machine. Please prepare for LAN cable connection beforehand.
  - Not compatible with SSL communication.

## Enable the event mail function

- 1 Press the **FUNC1** (MENU) ➔ **FUNC3** (>>) ➔ **ENTER** key in LOCAL.  
• MACHINE SETUP MENU will be displayed.
- 2 Press **▲▼** to select "EVENT MAIL", and press the **ENTER** key.
- 3 Press **▲▼** to select "MAIL DELIVERY", and press the **ENTER** key.
- 4 Press **▲▼** to select "ON", and press the **ENTER** key.
- 5 Press the **END/POWER** key several times to end the setting.

## Set the event to send an event mail

- 1 Press the **FUNC1** (MENU) ➔ **FUNC3** (>>) ➔ **ENTER** key in LOCAL.  
• MACHINE SETUP MENU will be displayed.
- 2 Press **▲▼** to select "EVENT MAIL", and press the **ENTER** key.
- 3 Press **▲▼** to select "SELECT EVENT", and press the **ENTER** key.
- 4 Press **▲▼** to select the "ON" or "OFF" of the event, then press the **ENTER** key.  
• Select the ON / OFF of the event in the order shown in the table below.  
After the ON / OFF setting, please proceed to the next event settings by pressing the [ENTER] key.  
• Press the [END / POWER] key when you return to the previous setting.

Event name	Outline
PRINT START	Sets sending/not sending of an email when printing starts.
PRINT END	Sets sending/not sending of an email when printing ends.
ERROR	Sets sending/not sending of an email when printing is stopped due to occurrence of an error.
WARNING	Sets sending/not sending of an email when a warning occurs during printing.
OTHER	Sets sending/not sending of an email when an event other than the above occurs.

- 5 Press the **END/POWER** key several times to end the setting.

## Set the e-mail address

- 1 Press the **FUNC1** (MENU)  $\rightarrow$  **FUNC3** (>>)  $\rightarrow$  **ENTER** key in LOCAL.
  - MACHINE SETUP MENU will be displayed.
- 2 Press  $\uparrow$   $\downarrow$  to select “EVENT MAIL”, and press the **ENTER** key.
- 3 Press  $\uparrow$   $\downarrow$  to select “MAIL ADDRESS”, and press the **ENTER** key.
- 4 Press  $\uparrow$   $\downarrow$   $\leftarrow$   $\rightarrow$  to set mail address, and press the **ENTER** key.
  - Set the e-mail address to which you send the event mail.
  - Set it with alphanumeric characters and symbols within 96 characters.
- 5 Press the **END/POWER** key several times to end the setting.

## Set the subject

- 1 Press the **FUNC1** (MENU)  $\rightarrow$  **FUNC3** (>>)  $\rightarrow$  **ENTER** key in LOCAL.
  - MACHINE SETUP MENU will be displayed.
- 2 Press  $\uparrow$   $\downarrow$  to select “EVENT MAIL”, and press the **ENTER** key.
- 3 Press  $\uparrow$   $\downarrow$  to select “MESSAGE SUBJECT”, and press the **ENTER** key.
- 4 Press  $\uparrow$   $\downarrow$   $\leftarrow$   $\rightarrow$  to set subject, and press the **ENTER** key.
  - Set the characters to write in the subject of the event mail.
  - Set it with alphanumeric characters and symbols within 8 characters.
- 5 Press the **END/POWER** key several times to end the setting.

## Set the server

- 1 Press the **FUNC1** (MENU)  $\rightarrow$  **FUNC3** (>>)  $\rightarrow$  **ENTER** key in LOCAL.
  - MACHINE SETUP MENU will be displayed.
- 2 Press  $\uparrow$   $\downarrow$  to select “EVENT MAIL”, and press the **ENTER** key.
- 3 Press  $\uparrow$   $\downarrow$  to select “SERVER SETUP”, and press the **ENTER** key.
- 4 Press  $\uparrow$   $\downarrow$  to select “SMTP ADDRESS”, and press the **ENTER** key.
- 5 Press  $\uparrow$   $\downarrow$   $\leftarrow$   $\rightarrow$  to set SMTP Address, and press the **ENTER** key.
  - Press the jog key [ $\uparrow$ ][ $\downarrow$ ][ $\leftarrow$ ][ $\rightarrow$ ] to set SMTP address.
  - Input the SMTP address name.
  - Set it with alphanumeric characters and symbols within 40 characters.
- 6 Press  $\uparrow$   $\downarrow$  to select “SMTP PORT No.”, and press the **ENTER** key.
- 7 Press  $\uparrow$   $\downarrow$  to set SMTP Port No., and press the **ENTER** key.
  - Set the SMTP port number.
- 8 Press  $\uparrow$   $\downarrow$  to select “SENDER MAIL ADDR”, and press the **ENTER** key.
- 9 Press  $\uparrow$   $\downarrow$   $\leftarrow$   $\rightarrow$  to set SENDER MAIL ADDRESS, and press the **ENTER** key.
  - Press [ $\uparrow$ ][ $\downarrow$ ][ $\leftarrow$ ][ $\rightarrow$ ] and set the e-mail address to be used as the sender mail address.
  - Set it with alphanumeric characters and symbols within 64 characters.
  - Depending on your server, if you do not set the e-mail address not supporting the account, sending/ receiving e-mails may be unavailable.
- 10 Press  $\uparrow$   $\downarrow$  to select “AUTHENTICATION”, and press the **ENTER** key.
- 11 Press  $\uparrow$   $\downarrow$  to set authentication method, and press the **ENTER** key.
  - Set the authentication method of the SMTP server.
  - When you select [OFF], proceed to the Step 20.



- 12** Press **[▲][▼]** to select “USER NAME” , and press the **[ENTER]** key.
- 13** Press **[▲][▼][◀][▶]** to set User Name, and press the **[ENTER]** key.
- Press **[▲][▼][◀][▶]** to set the user name to use for the authentication.
  - Set it with alphanumeric characters and symbols within 30 characters.
- 14** Press **[▲][▼]** to select “PASSWORD” , and press the **[ENTER]** key.
- 15** Press **[▲][▼][◀][▶]** to set Pass Word, and press the **[ENTER]** key.
- Press **[▲][▼][◀][▶]** to set the password to use for the authentication.
  - Set it with alphanumeric characters and symbols within 15 characters.
  - On the password setting screen, you can only check the value that you are currently inputting.
  - When you select [POP before SMTP] in the Step 9, set the items in the Step 14 to 17.
- 16** Press **[▲][▼]** to select “POP3 ADDRESS” , and press the **[ENTER]** key.
- 17** Press **[▲][▼][◀][▶]** to set POP3 Address, and press the **[ENTER]** key.
- Press **[▲][▼][◀][▶]** to set POP server.
  - Input the POP server name.
  - Set it with alphanumeric characters and symbols within 40 characters.
- 18** Press **[▲][▼]** to select “APOP” , and press the **[ENTER]** key.
- 19** Press **[▲][▼]** to set ON/ OFF, and press the **[ENTER]** key.
- 20** Press the **[END/POWER]** key several times to end the setting.

## Send a test e-mail

- 1** Press the **[FUNC1 (MENU)]** → **[FUNC3 (>>)]** → **[ENTER]** key in LOCAL.
- MACHINE SETUP MENU will be displayed.
- 2** Press **[▲][▼]** to select “EVENT MAIL” , and press the **[ENTER]** key.
- 3** Press the **[FUNC3 (>>)]** → **[ENTER]** key.
- “TRANSMIT TEST EXECUTE” will be displayed.
- 4** Press the **[ENTER]** key.
- The sent result is displayed.
  - If sending test e-mail has failed, an error code is displayed.  
Refer to the next page to solve the problem.

```

TRANSMIT TEST
FAILED: 12345 <ent>

```

Error code

- 5** Press the **[END/POWER]** key several times to end the setting.



- The sent result of the test e-mail is the result of e-mail sending process performed by this machine to the e-mail server. It does not indicate that the e-mail was received at the address.
- If the spam e-mail filter etc. has been set in the terminal in which e-mails are received, even if "Sending has been completed" is displayed, the e-mail cannot be received in some cases.
- If sending test e-mail has failed, the error code below is displayed.
- If the error cannot be solved, try again after a while.
- For the server setting etc., contact with the network administrator or the provider.

Error Code	The expected casus	Remedy
<b>10</b>	Network connection error	<ul style="list-style-type: none"> <li>• Check that the machine is connected with the network.</li> <li>• Check that the machine IP address is correct.</li> <li>• Check that the machine is in the environment where DNS is available.</li> </ul>
<b>20</b>	No valid e-mail address.	<ul style="list-style-type: none"> <li>• Enter the correct e-mail address.</li> </ul>
<b>11003</b> <b>11004</b>	The POP server cannot be found. Or cannot access DNS server.	<ul style="list-style-type: none"> <li>• Check the POP server address.</li> <li>• Check that the machine is in the environment where DNS is available.</li> </ul>
<b>11021</b>	Cannot connect with the POP server.	<ul style="list-style-type: none"> <li>• Check the POP server setting.</li> <li>• Check the firewall setting.</li> </ul>
<b>12010</b>	An error returns from the POP server.	<ul style="list-style-type: none"> <li>• Check the POP server setting.</li> </ul>
<b>13000</b>	The POP authentication has failed.	<ul style="list-style-type: none"> <li>• Check the user name and the password.</li> <li>• Check the APOP setting.</li> <li>• Confirm the authentication method.</li> </ul>
<b>10013</b> <b>10014</b>	The SMTP server cannot be found. Or cannot access DNS server.	<ul style="list-style-type: none"> <li>• Check the SMTP server address.</li> <li>• Check that the machine is in the environment where DNS is available.</li> </ul>
<b>10021</b>	Cannot connect with the SMTP server.	<ul style="list-style-type: none"> <li>• Check the SMTP server setting.</li> <li>• Check the SMTP port number.</li> <li>• Check the firewall setting.</li> </ul>
<b>10***</b> <b>11***</b> <b>20***</b> <b>21***</b>	An error returns from the SMTP server. Or, there was no response.	<ul style="list-style-type: none"> <li>• Check the SMTP server setting.</li> <li>• Cannot communicate with a server that requires mandatory SSL communication.</li> <li>• Check protocol filter settings.</li> </ul>
<b>12***</b>	It is invalid sender address.	<ul style="list-style-type: none"> <li>• Check that the e-mail address supporting the account entered in the user name/ the password is set in SENDER ADDRESS.</li> </ul>
<b>13***</b>	The e-mail address cannot be found. Or, it is invalid sender address.	<ul style="list-style-type: none"> <li>• Check the e-mail address.</li> <li>• Even if there is a mistake in the e-mail address, this error cannot be detected in some cases.</li> <li>• Check that the e-mail address supporting the account entered in the user name/ the password is set in SENDER ADDRESS.</li> </ul>
<b>22000</b> <b>22008</b>	SMTP authentication error	<ul style="list-style-type: none"> <li>• Confirm the authentication method.</li> </ul>
<b>23***</b> <b>24***</b> <b>25***</b>	The SMTP authentication has failed.	<ul style="list-style-type: none"> <li>• Check the user name and the password.</li> </ul>

“\*\*\*” is the error code returned from the e-mail server.

## Setting a LANGUAGE

You can change the displayed language.

- 1 Press the **FUNC1** (MENU) ➡ **FUNC3** (>>) ➡ **ENTER** key in LOCAL.
  - MACHINE SETUP MENU will be displayed.
- 2 Press **FUNC1** to select “LANGUAGE”, and press the **ENTER** key.
- 3 Press **▲** **▼** to select language, and press the **ENTER** key.
  - Set Value : 日本語 / English / Deutsch / Français / Español / Italiano / Português
- 4 Press the **END/POWER** key several times to end the setting.

## Initializing the Settings

You can return the setting of “SETUP”, “MAINTENANCE” and “MACHINE SETUP” to the status before shipment.

- 1 Press the **FUNC1** (MENU) ➡ **FUNC3** (>>) ➡ **ENTER** key in LOCAL.
  - MACHINE SETUP MENU will be displayed.
- 2 Press the **FUNC1** (<<) key.
- 3 Press **▲** **▼** to select “SETUP RESET”, and press the **ENTER** key.
- 4 Press the **ENTER** key.
  - The already configured settings are initialized.
- 5 Press the **END/POWER** key several times to end the setting.

# About NOZZLE CHECK MENU

Set operations concerning the nozzle missing detection function.

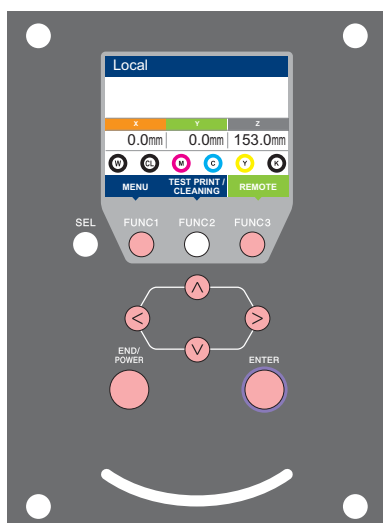

- FUNC1** : Press this to select INFORMATION MENU, or to switch to the previous screen.
- FUNC3** : Press this to switch to the next screen.
- ▲ ▼** : Use these to select a setting item.
- ENTER** : Press this to confirm a setting, etc..

## ◆ NCU MENUs at-a-glance

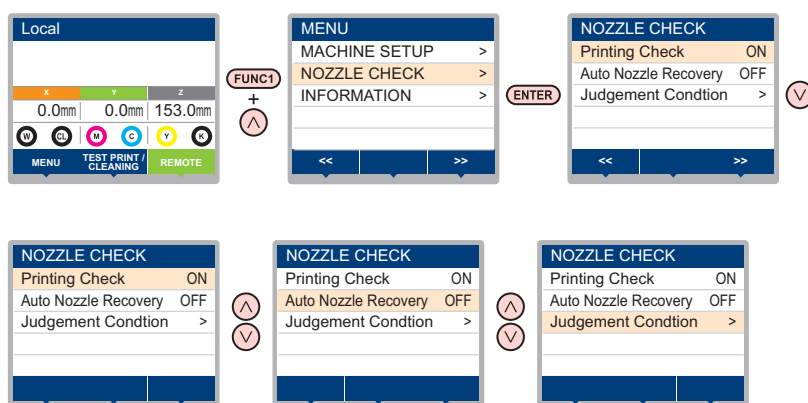

## INFORMATION MENU table

Function name		Set value	Default	Meaning	
(ON)	Printing Check ((P.3-24))	LENGTH	0.1 to 50.0m	30.0 m	Conducts nozzle check at each set length.
		FILE	1 to 100	30 file	Conducts nozzle check at each set number of files. *1
	Action	CLEANING	OFF/ SOFT/ NORMAL/ HARD	SOFT	Sets the type of cleaning performed during recovery work.
		RETRY COUNT	0 to 3	1	Repeats the retry operation for the set number of times.
NOZZLE RECOVERY ((P.3-24))		ON/OFF	OFF	Set this when you want to conduct automatic nozzle recovery.	
Judgement Condition ((P.3-24))		1 to 180	1	Sets how many missing nozzles are detected for "Nozzle Missing" judgment to be made according to each color. (Maximum 16 per 1 nozzle line)*2	

\*1. When the set length is reached during printing, nozzle check is conducted at the start of the next printing.

\*2. Depending on the print conditions, nozzle recovery is not applied in some cases.

## Printing Check Flow

Nozzle check is conducted according to the following flow at the start of printing.



- Turn the “Printing Check” setting ON to be enabled.
- Only perform RETRY COUNT and Printing Check settings when the settings are enabled.

### 1 nozzle check → Judgment

Detects missing nozzles.

### 2 Recovery operation → nozzle check → Judgment

If more missing nozzles than “Judgement Condition ” are detected after the nozzle check, cleaning is performed and nozzle check is conducted again.

### 3 Retry → Judgment

If more missing nozzles than “Judgement Condition ” are detected after the recovery operation, the recovery operation is conducted again.

### 4 Printing Check → Judgment

Nozzle recovery is automatically conducted following nozzle check and recovery operation.

- Turn the “Printing Check” setting ON to be enabled.

### 5 Nozzle Missing judgment

If more missing nozzles than A are eventually detected, continued printing will be deemed impossible and printing will stop.

3

## Printing Operations at “Nozzle Missing” Judgment and Error Occurrence

- **When judged to be “Nozzle Missing”** → Printing is stopped.
- **When error occurs during nozzle check** → Printing is stopped and “Printing Check” is automatically turned OFF. After recovering from the error, set “Printing Check” once again.

## Setting the Printing Check

Select ON when you want to conduct nozzle check at the start of online printing.

- 1 Press the **FUNC1 (MENU)** → **FUNC3** → **▼** (1 time) → **ENTER** key in LOCAL.
  - NOZZLE CHECK MENU will be displayed.
- 2 Press **▲** **▼** to select “Printing Check”, and then press the **ENTER** key.
- 3 Press **▲** **▼** to select ON, and then press the **ENTER** key.
  - The “Check Interval” setting screen will be displayed.
  - “Select OFF to not set nozzle check. Proceed to Step 11.
- 4 Press the **ENTER** key.
- 5 Press **▲** **▼** to select setting item, and then press the **ENTER** key.
  - select the nozzle check interval from “LENGTH” or “FILE”.
    - LENGTH:** nozzle check is conducted when the printed length reaches the set length.
    - FILE:** nozzle check is conducted when the number of printed files reaches the set number.
- 6 Press **▲** **▼** to select setting value, and then press the **ENTER** key.
  - The set value will differ according to the setting selected in Step 5.
    - LENGTH:** 0.1 to 100 m
    - FILE:** 0 to 300 files
- 7 Press the **ENTER** key twice.
  - The “Action” setting screen will be displayed.
- 8 Press the **ENTER** key.
  - “CLEANING TYPE” will be selected.
- 9 Press **▲** **▼** to select cleaning type, and then press the **ENTER** key.
 

Setting value: OFF/SOFT/ NORMAL/ HARD
- 10 Press **▲** **▼** to select retry count, and then press the **ENTER** key.
 

Setting value: 0 to 3
- 11 Press the **END/POWER** key several times to end the setting.

## Setting the NOZZLE RECOVERY

set this if you want to conduct automatic nozzle recovery when nozzle missing is detected.

- 1 Press the **FUNC1 (MENU)** → **▼** (3 times) → **ENTER** key in LOCAL.
  - NOZZLE CHECK MENU will be displayed.
- 2 Press **▲** **▼** to select “NOZZLE RECOVERY”, and then press the **ENTER** key.
- 3 Press **▲** **▼** to select ON/OFF, and then press the **ENTER** key.
- 4 Press the **END/POWER** key several times to end the setting.

## Setting the Judgement Condition

Set the conditions for judging nozzle missing.

- 1 Press the **FUNC1 (MENU)** → **▼** (3 times) → **ENTER** key in LOCAL.
  - NOZZLE CHECK MENU will be displayed.
- 2 Press **▲** **▼** to select “Judgement Condition”, and then press the **ENTER** key.
- 3 Press **▲** **▼** to select color, and then press the **ENTER** key.
  - The type of color changes depending on the ink set.
 
- 4 Press **▲** **▼** to set the number of nozzles for judgment, and then press the **ENTER** key.
- 5 Press the **END/POWER** key several times to end the setting.



# About INFORMATION MENU

The information of this machine can be confirmed.  
The following items can be confirmed as machine information.

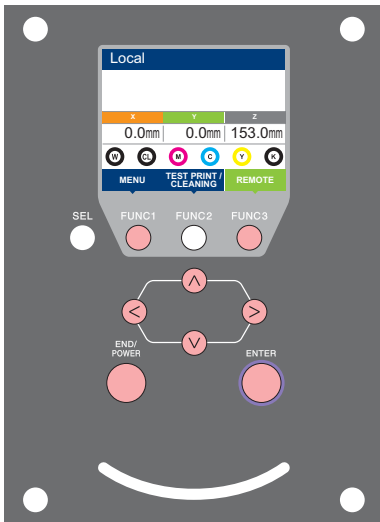

- FUNC1** : Press this to select INFORMATION MENU, or to switch to the previous screen.
- FUNC3** : Press this to switch to the next screen.
- ▲▼** : Use these to select a setting item.
- ENTER** : Press this to confirm a setting, etc..

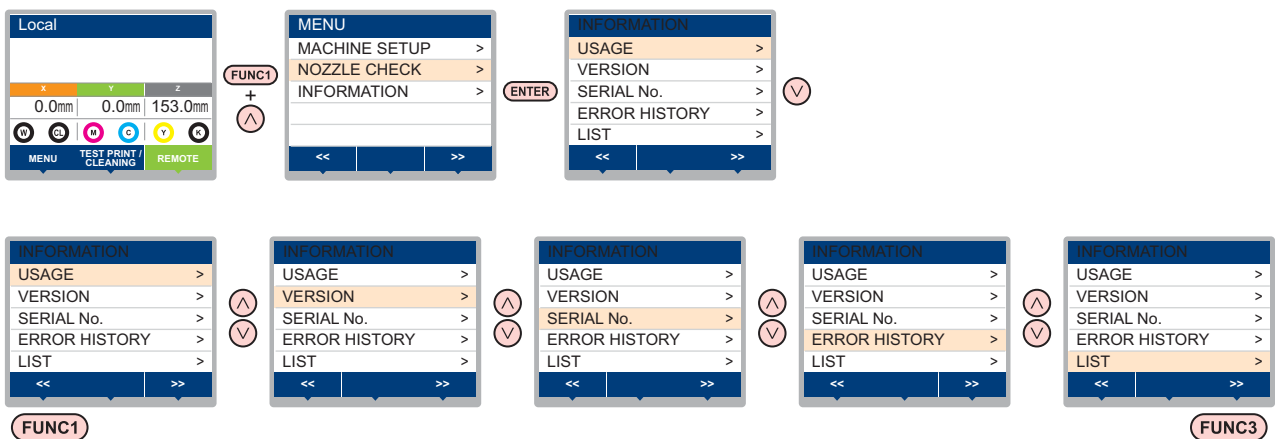

3

## INFORMATION MENU table

Item		Description
USAGE	WIPING	This displays how many wipings have been done.
	WASTE TANK	This displays how much waste ink has built up in the waste ink tank, as a rough percentage of the tank capacity.
	PRINT LENGTH	This displays the total length of the printing done to date.
	PRINT AREA	This displays the total area of the printing done to date.
	USE TIME	This displays the total time for which the machine has been used to date.
VERSION		This displays the version information of this machine.
SERIAL NO.		This displays the serial number information of this machine.
ERROR HISTORY		This displays the history of errors and warnings to date. When you press [▲][▼], the date of occurrence (year/month/day/hour/minute) and the error/warning information are displayed alternately in the order of occurrence.
LIST		This allows you to print the settings of this machine.

## Displaying the Information

**1** Press the **FUNC1** (MENU) → **FUNC3** → **▼** (2 times) → **ENTER** key in LOCAL.

- INFORMATION MENU will be displayed.

**2** Press **▲** **▼** to select a information.

- Refer to the "INFORMATION MENU", and select the information to be displayed.

**3** Press the **ENTER** key.

- If you selected [LIST] in step 2, the machine's settings will be printed.

**4** Press the **END/POWER** key several times to end the setting.

# Chapter 4

## Maintenance



### This chapter

describes the items required to use this machine more comfortably, which are the methods for the daily care, the maintenance of the ink bottles etc.

Routine maintenance .....	4-2	Setting Interval wiping .....	4-10
When this machine is left unused for a long time .....	4-2	Changing the Time When a Warning about Wiper Replacement Is Issued .....	4-11
Precautions in cleaning .....	4-2	Checking the Head Gaps at the Four Corners of the Table .....	4-11
Cleaning exterior surfaces .....	4-2	Checking Ink Landing Displacement .....	4-11
Cleaning the table .....	4-3	Solving the Ink Overflow Problem .....	4-12
About MAINTENANCE MENU .....	4-4	Replacing consumables .....	4-12
MAINTENANCE MENUs at-a-glance .....	4-5	If a Waste Ink Tank Confirmation Message Appears .....	4-12
Maintaining the Capping Station .....	4-6	Replacing the waste ink tank before the waste ink tank confirmation message is displayed .....	4-14
Cleaning the Wiper and Cap .....	4-6	Refilling antifreeze mixed water .....	4-14
Washing the Ink Discharge Passage .....	4-7	Refill antifreeze mixed water .....	4-15
Cleaning the Ink Head and the Area around It .....	4-8		
Nozzle Recovery Function .....	4-9		
Reset the set value .....	4-10		
Checking the UV Lamp Usage .....	4-10		

## Routine maintenance

Be sure to conduct maintenance works for the machine depending on operation frequency or periodically so as to use the machine for a long time while keeping its drawing accuracy.

### When this machine is left unused for a long time

When the machine is not going to be used for a week or more, use the cleaning function for ink discharge passage. After this, keep the machine in custody.



- Use the machine with always turning "ON" the main power.
- Remove the media being set.

### Precautions in cleaning



- Never disassemble this machine. Disassembling this machine can result in electric shock hazards or damage to this machine.
- Prevent moisture from entering this machine. Moisture inside the machine can result in electric shock hazards or damage to this machine.
- Before starting maintenance work, be sure to turn off the main power switch and unplug the power cable; otherwise, an unexpected accident may occur.
- Do not use benzine, thinner, or any chemical agent containing abrasives. Such materials can deteriorate or deform the surface of the covers.
- Do not apply lubricating oil or the like to any part inside this machine. Such materials can cause this machine mechanism to fail.
- In case water or alcohol mixed into the UV curing ink (UV ink), flocculation would be occurred. Be sure not to adhere water or alcohol not only on the nozzle and also near the head.



- This machine uses UV curing ink (UV ink). When in daily care, be sure to put on the supplied goggles.

### Cleaning exterior surfaces

If exterior surfaces of the machine is dirty, dampen a soft cloth with water or a neutral detergent diluted with water, squeeze it and wipe the surfaces.

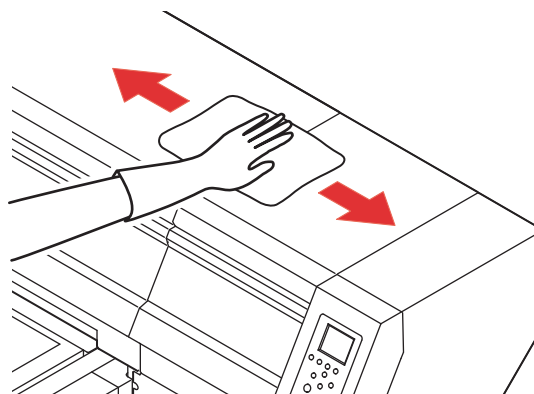

## Cleaning the table

The table is easy to become dirt with lint, paper dust or the like after cutting media.

For a conspicuous stain, wipe it off with a soft-hair brush, a dry cloth, a paper towel or the like.

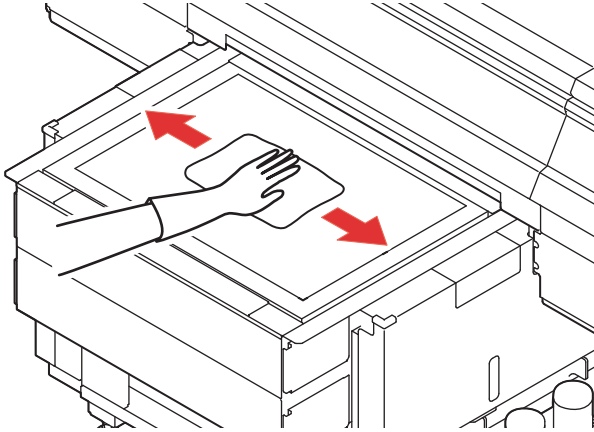

**Important!**

- Be sure to clean the slot on the frame of the table, the screw holes for holding tools or the like since dust and dirt are easily accumulated in these parts.



- If it is stained with ink, wipe it off with a paper towel containing a little amount of the cleaning solution.

# About MAINTENANCE MENU

This provides various settings for doing maintenance on the machine.  
The following items can be set in Maintenance settings.

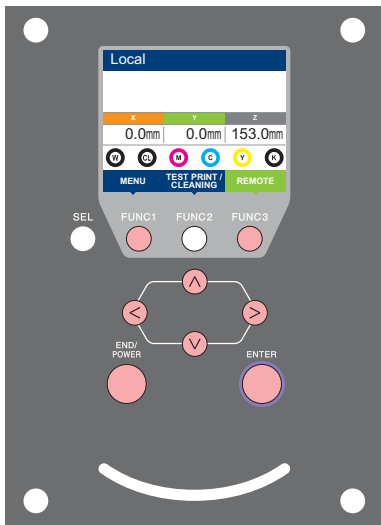

- FUNC1** : Press this to select MAINTENANCE MENU, or to switch to the previous screen.
- FUNC3** : Press this to use the maintenance function.
- ▲ ▼** : Press this to switch to the next screen.
- ENTER** : Use these to select a setting item.
- ▶ ◀** : Press this to confirm a setting, etc..

## ◆ MAINTENANCE MENUs at-a-glance

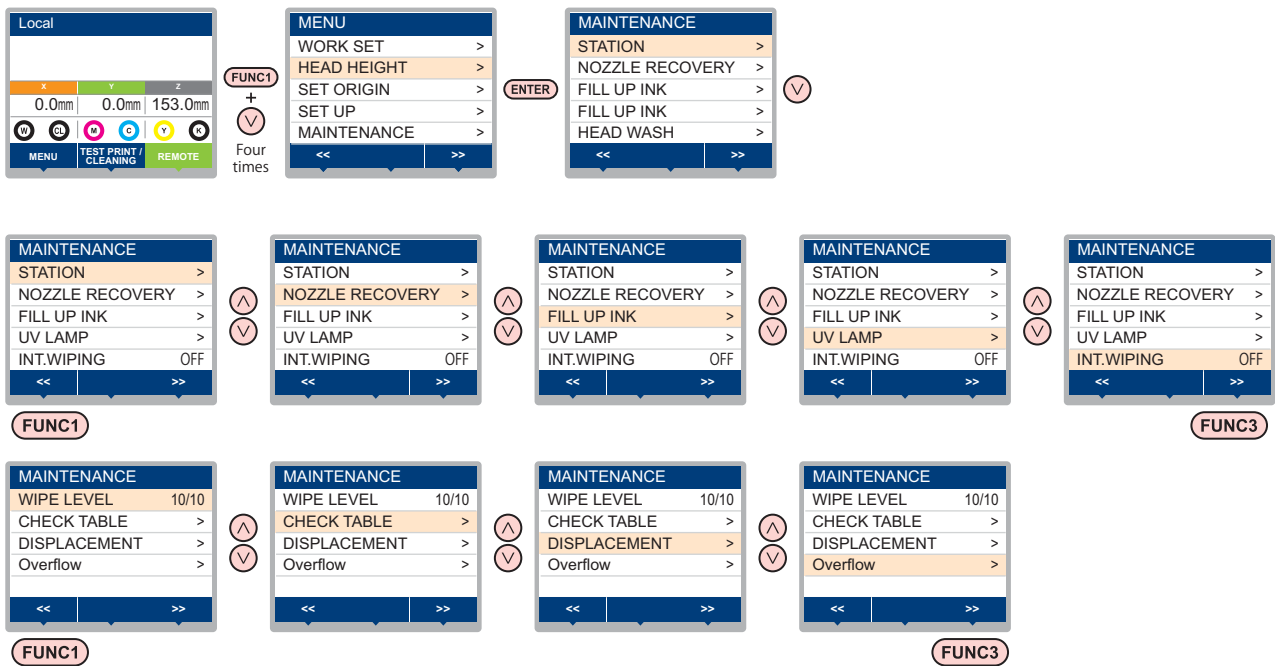

## MAINTENANCE MENUs at-a-glance

Item	Set value	Meaning
STATION MAINTENANCE	For carrying out maintenance on the carriage and station periphery.	
	CARRIAGE OUT (☞ P.4-6)	_____ Moves the carriage out, for carrying out cleaning of the cap periphery, head, wipers, etc.
	WIPER CLEANING (☞ P.4-11)	Soaks the nozzle surfaces in maintenance cleaning fluid, for carrying out recovery from nozzle clogging or bent.
	WASTE TANK ( )	Resets or corrects the used count for the waste ink tank.
	DISWAY WASH (☞ P.4-7)	_____ Wash the ink discharge passage
NOZZLE RECOVERY (☞ P.4-9)	For printing using another nozzle, if nozzle wash and so forth fail to effect recovery from nozzle clogging, etc.	
	PRINT	Prints a pattern, to identify the nozzle that is clogged.
	ENTRY	Registers the faulty nozzle identified by "PRINT".
	RESET	Resets a registered faulty nozzle.
UV LAMP (☞ P.4-10)	UV USED TIME	This displays the total time for which each of the UV lamps has been illuminated.
INT. WIPING(☞ P.4-10)	OFF, 1~255	Sets the wiping operation performed after printing is completed.
WIPE LEVEL(☞ P.4-11)	1/10~10/10	Changing the time when a warning about wiper replacement is issued.
CHECK TABLE (☞ P.4-11)	For individually moving the head to one of the four table corners to check the head gaps.	
DISPLACEMENT (☞ P.4-11)	For checking if ink landing displacement is present due to unstable installed table or other similar behavior.	
Overflow (☞ P.4-12)	For discharging excessive ink in the sub tank to solve the ink overflow problem.	

# Maintaining the Capping Station

Maintain the ink cap, wiper, etc. located in the capping station. (SATION MAINT.)



- To keep the nozzle status normal, perform wiper cleaning frequently.

The ink cap and wiper function as follows.

- **Wiper** : It wipes off ink sticking to the head nozzles.
- **Ink cap** : It prevents the head nozzles from clogging due to dryness.

As the machine is used repeatedly, the wiper and ink cap gradually become dirty with ink, dust, etc.

If nozzle missing cannot be corrected even after head cleaning (P.2-7) has been performed, use a f-200 / lf-200 Washing Liquid kit and cleaning swab.

## Tools required for Maintenance

• F-200 / LF-200 Washing Liquid (SPC-0568)		
• UJ Cleaning swab (SPC-0386)	• Gloves	• Goggles



- Be sure to wear the supplied goggles and gloves when maintaining the capping station. Otherwise, you may get ink in your eyes.
- Do not move the carriage out of the capping station by hand. When it is desirable to move the carriage, press the [FUNK1] key to execute the carriage-out. (P.4-6Steps 1 to 2)

## Cleaning the Wiper and Cap

It is recommended that the wiper and cap be cleaned frequently in order to maintain the high image quality of the machine and keep the machine itself in good working order.



- Even if you cleaned the wiper, when Nozzle out or Ink dropping cannot be solved, try to replace the nozzle.
- If the dirt of the wiper is heavy, replace the nozzle (SPA-0274).

# 1

Press the **FUNC1 (MENU)** **(4 times)** key in LOCAL.

- MAINTENANCE MENU will be displayed.

# 2

Press the **ENTER** key.

- The carriage moves to the left.

# 3

Open the right front cover.

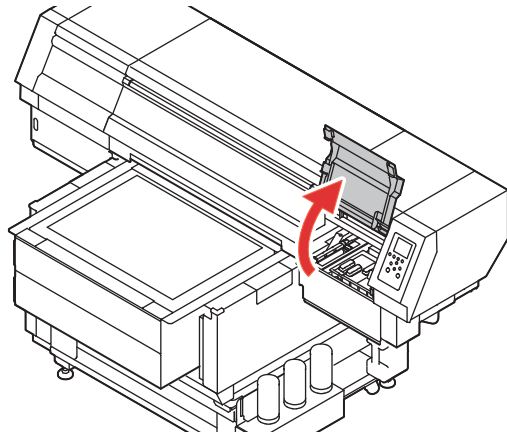

# 4

Dip the washing liquid into the cleaning swab, and wipe dirt of the wiper nozzle.

- Wipe the places shown in the right.
- If the dirt of the wiper is heavy, replace the nozzle (SPA-0274).

When fitting the nozzle, be careful not to put back to front.

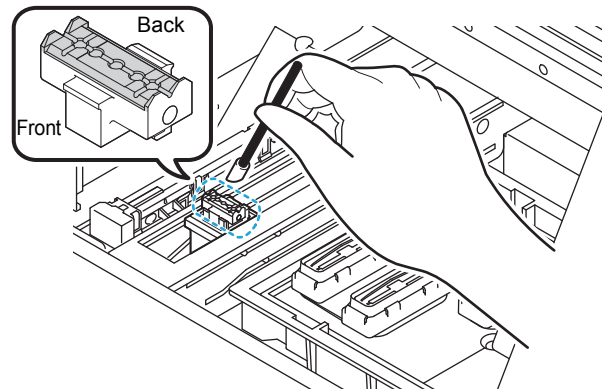

# 5

Clean the cap rubber.

- Wipe off the ink sticking to the cap rubber with a cleaning swab dipped in maintenance solution for maintenance.

Wipe off so that maintenance solution for maintenance will not remain.

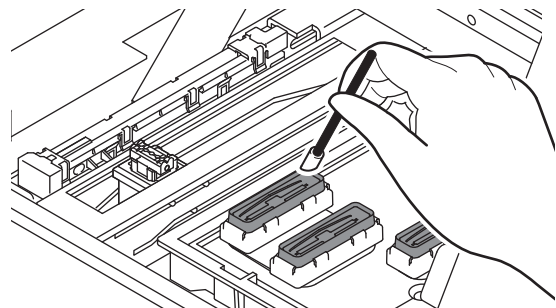



**6** Press the **ENTER** key after the cleaning.

**7** Close the front cover then press the **ENTER** key.

- After its initial operation, the machine returns to step1.

### Washing the Ink Discharge Passage

Wash the ink discharge passage regularly (about once a week) to prevent the head nozzles from clogging due to ink coagulation inside the passage.

**1** Press the **FUNC1** (MENU)  $\rightarrow$   $\nabla$  (4 times)  $\rightarrow$  **ENTER** key in LOCAL.

- MAINTENANCE MENU will be displayed.

**2** Press the **ENTER** key.

- "STATION" will be selected.

**3** Press  $\nabla$  twice, and press the **ENTER** key.

- "DISWAY WASH" will be selected and the carriage will moves to the center.
- Dry suction operation is performed repeatedly until the washing work is completed.

**4** Open the right front cover.

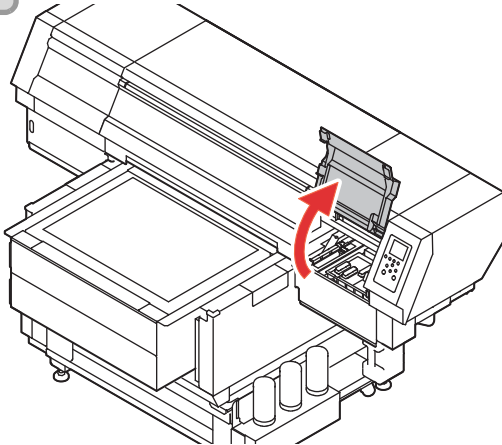

**5** Press the **ENTER** key.

- Dry suction operation is performed repeatedly until the washing work is completed.

**6** Put a maintenance cleaning liquid into the ink discharge passage.

- Using a pipette, put 20 cc of a maintenance cleaning liquid into the passage through the hole in the center of the cap slider.

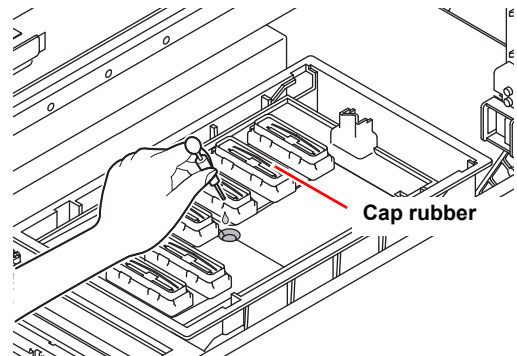

**7** Close the front cover and press the **ENTER** key.

# Cleaning the Ink Head and the Area around It

Because the ink head employs a very precise mechanism, due care needs to be taken when it is cleaned.

Using a cleaning swab, etc., rub off gelatinous ink or dust that may stick to the lower part of the slider and the area around the ink head. In doing so, never rub the nozzles of the head.

Tools required for cleaning	
• UJ Cleaning swab (SPC-0386)	• Gloves
• Goggles	• Washing Liquid



- Be sure to wear the attached goggles and gloves when cleaning the area around the ink head. Otherwise, you may get ink in your eyes.
- The ink contains organic solvent. If you get the ink on your skin or in your eyes, wash it away with plenty of water immediately.

**1** Press the **FUNC1 (MENU)**  $\rightarrow$  **▼** (4 times)  $\rightarrow$  **ENTER** key in LOCAL.  
 • MAINTENANCE MENU will be displayed.

**2** Press the **ENTER** key.  
 • "CARRIAGE OUT" will be selected.

**3** Press **▼**, and press the **ENTER** key.  
 • Carriage will move to the left end of this machine.

**4** Open the maintenance cover.

**5** Remove the H maintenance cover.

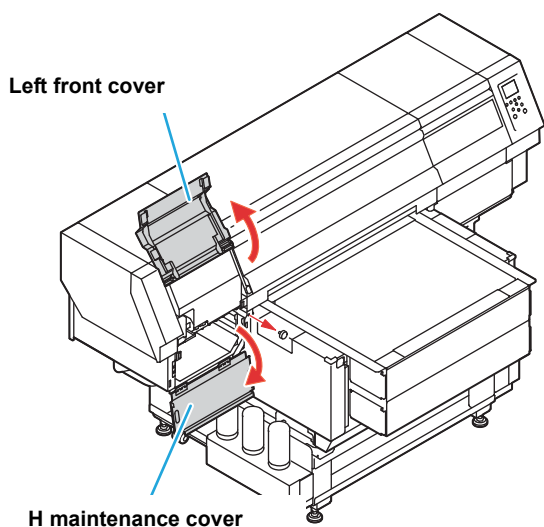

**6** Wipe ink sticking to the side of the head off with a cleaning swab.

- Never rub the nozzles.

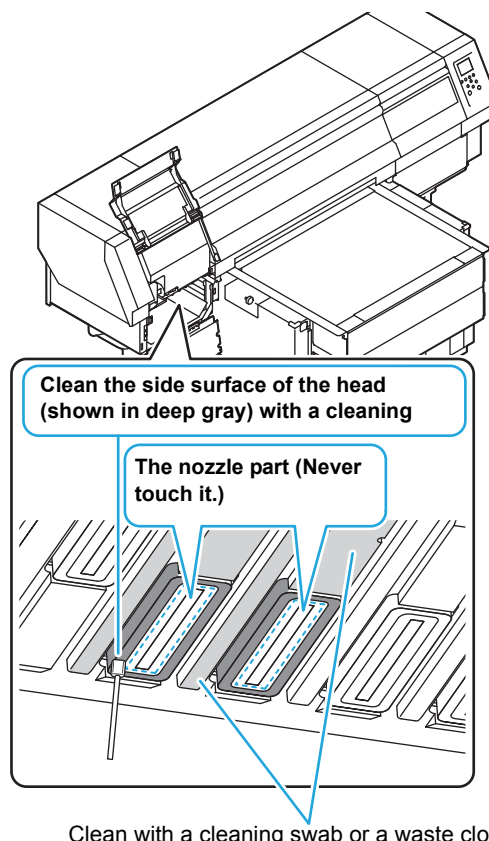

**7** Press the **ENTER** key after the cleaning.

**8** Close the maintenance cover, and press the **ENTER** key.  
 • After its initial operation, the machine returns to LOCAL.

# Nozzle Recovery Function

**NOZZLE RECOVERY:** When nozzles missing can not be improved at specific points, other good nozzles can be used as alternatives for printing.

**1** Press the **[FUNC1] (MENU)** **[▼]** (4 times) **[ENTER]** key in **LOCAL**.

- MAINTENANCE MENU will be displayed.

**2** Press **[▲]****[▼]** to select **"RECOVERY"**, and press the **[ENTER]** key.

**3** Press **[▲]****[▼]** to select **"PRINT"** and press the **[ENTER]** key twice.

- Printing of the nozzle pattern will start.
- Select "ENTRY" then "Move to select of the Nozzle line (Step 4) without drawing a pattern"

Overhead view

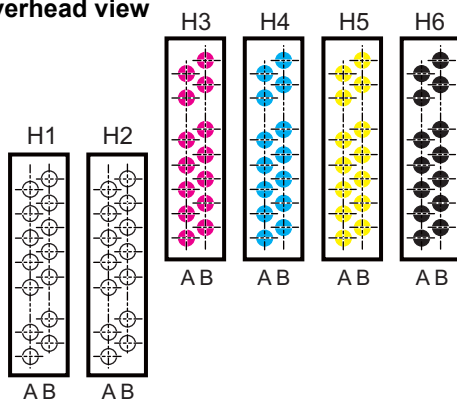

Nozzle pattern

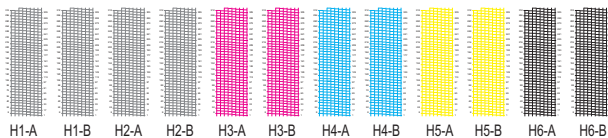

**4** Press **[▲]****[▼]** to select **"Entry"** and press the **[ENTER]** key twice.

**5** Select the Nozzle line that needs **NOZZLE RECOVERY** by pressing **[▲]****[▼]**, and press key.

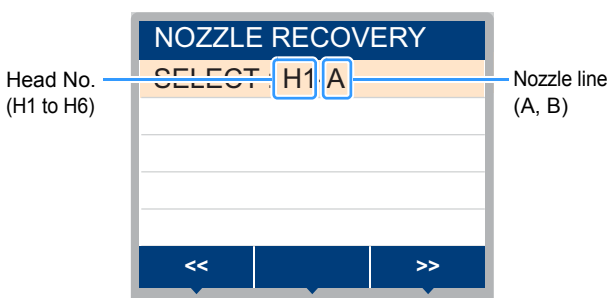

**6** Register the Nozzle number that needs **NOZZLE RECOVERY** and press **[ENTER]** key.

- (1) Select the registration number from 1 to 10 by pressing **[▲]****[▼]** key and press the **[ENTER]** key.
- (2) Register the nozzle number that needs recovery by pressing **[▲]****[▼]** key and press the **[ENTER]** key.

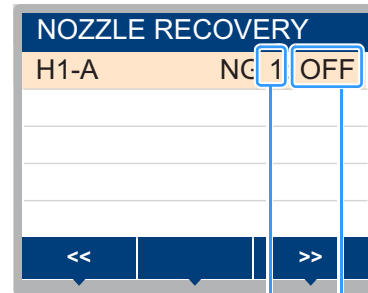

Registration number : 1 to 10

Recovery nozzle No.: 1 to 318, OFF

Example of nozzle to be recovered

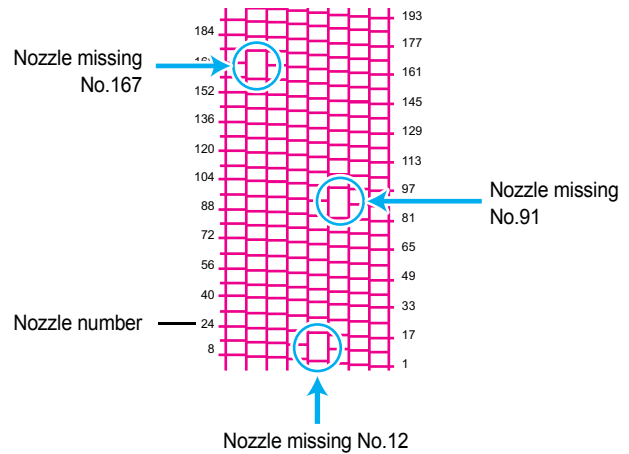

Registration number	Recovery Nozzle No.	State
1	12	Target for nozzle recovery
2	91	Target for nozzle recovery
3	167	Target for nozzle recovery
4	OFF	No registration
5	OFF	No registration

**7** Press the **[END/POWER]** key several times to end the setting.



- Up to 10 nozzles can be registered per 1 nozzle line.
- Even if you use this function, time required for drawing does not change.
- When printing has been done with the lowest path, nozzle recovery is not reflected. Perform test printing to confirm.



- When you use white ink, print on the clear film to check.

## Reset the set value

- 1 Press the **FUNC1** (MENU)  $\rightarrow$  **▼** (4 times)  $\rightarrow$  **ENTER** key in LOCAL.
  - MAINTENANCE MENU will be displayed.
- 2 Press **▲▼** to select “NOZZLE RECOVERY”, and press the **ENTER** key.
- 3 Press **▲▼** to select “Reset”, and press the **ENTER** key.
- 4 Press **▲▼** and **FUNC1** (PAGE>) **FUNC3** (<<) to select the Nozzle line that need reset, and press the **ENTER** key.
  - A reset confirmation message will be displayed.
- 5 Press the **END/POWER** key several times to end the setting.

## Checking the UV Lamp Usage

### Checking Uv Lamp Use Time

- 1 Press the **FUNC1** (MENU)  $\rightarrow$  **▼** (4 times)  $\rightarrow$  **ENTER** key in LOCAL.
  - MAINTENANCE MENU will be displayed.
- 2 Select “UV USED TIME”, and press the **ENTER** key.
  - The use time is displayed for each of the UV lamps.
- 3 Press the **END/POWER** key several times to end the setting.

## Setting Interval wiping

When a set time has elapsed, the machine automatically wipes the nozzle surfaces of the head to remove any ink droplets attached to the surfaces.

In case that deflection, nozzle missing, or symptom which ink droplets fall down occurred, set the interval between each operation shorter.

- 1 Press the **FUNC1** (MENU)  $\rightarrow$  **▼** (4 times)  $\rightarrow$  **ENTER** key in LOCAL.
  - MAINTENANCE MENU will be displayed.
- 2 Press **▲▼** to select “Interval Wiping”, and press the **ENTER** key.
- 3 Press **▲▼** to set intervals.
  - Set Value : 1 to 255 Times, OFF
  - When [OFF] is set, periodical wiping is not executed.
- 4 Press the **ENTER** key.
- 5 Press the **END/POWER** key several times to end the setting.

**Important!**

- The color tone may change, depending on the timing when periodic wiping is performed. Check in advance that the color tone is not affected.

## Changing the Time When a Warning about Wiper Replacement Is Issued

The wiper is consumable. Wiper levels can be set so that a warning about wiper replacement is issued earlier than the standard according to the operating environment.

10/10	Displays the wiper replacement warning when wiping has been performed the standard number of times. (Initial value)
9/10	Displays the wiper replacement warning when wiping has been performed nine tenths of the standard number of times.
8/10	Displays the wiper replacement warning when wiping has been performed eight tenths of the standard number of times.
⋮	
1/10	Displays the wiper replacement warning when wiping has been performed one tenth of the standard number of times.

**1** Press the **FUNC1** (MENU)  $\rightarrow$   $\downarrow$   $\rightarrow$  **ENTER** key in LOCAL.

- MAINTENANCE MENU will be displayed.

**2** Press  $\uparrow$   $\downarrow$  to select "FILL UP INK", and press the **ENTER** key.

**3** Press  $\uparrow$   $\downarrow$  to set a wiper level, and press the **ENTER** key.

- Set value : 1/10 to 10/10

**4** Press the **ENTER** key.

**5** Press the **ENTER** key several times to end the setting.

## Checking the Head Gaps at the Four Corners of the Table

**1** Press the **FUNC1** (MENU)  $\rightarrow$   $\downarrow$  (4 times)  $\rightarrow$  **ENTER** key in LOCAL.

- MAINTENANCE MENU will be displayed.

**2** Press the **FUNC1** (<<).

**3** Press  $\uparrow$   $\downarrow$  to select "CHECK TABLE", and press the **ENTER** key.

**4** Press  $\uparrow$   $\downarrow$  to select the checking positions.

- Set Value : RIGHT & REAR, RIGHT & FRONT, LEFT & FRONT, LEFT & REAR

**5** Press the **ENTER** key.

- The table or carriage moves to the measuring position.

**6** Press the **END/POWER** key several times to end the setting.

## Checking Ink Landing Displacement

You can check for ink landing displacement from causes such as the equipment table shaking.

**1** Press the **FUNC1** (MENU)  $\rightarrow$   $\downarrow$  (4 times)  $\rightarrow$  **ENTER** key in LOCAL.

- MAINTENANCE MENU will be displayed.

**2** Press the **FUNC1** (<<).

**3** Press  $\uparrow$   $\downarrow$  to select "DISPLACEMENT", and press the **ENTER** key.

**4** Press the **ENTER** key.

- Printing starts.







**5** Press the **END/POWER** key several times to end the setting.

**Important!**

- Ink landing displacement will result in a striped pattern.

Check that the table does not shake and that there is not a large head gap. If there is a large ink landing displacement, request service to readjust the device.

## Solving the Ink Overflow Problem

- 1 Press the **FUNC1** (MENU)   (4 times)  **ENTER** key in LOCAL.
  - MAINTENANCE MENU will be displayed.
- 2 Press the **FUNC1** (<<).
- 3 Press   to select “Overflow”, and press the **ENTER** key.
- 4 Press   to select head.
- 5 Press the **ENTER** key.
- 6 Press the **END/POWER** key several times to end the setting.

**Important!**

- Repeat this procedure if you cannot solve the problem after performing it once. If you still cannot solve the problem even after performing this procedure three times, contact the distributor in your region or our service office.

## Replacing consumables



### If a Waste Ink Tank Confirmation Message Appears

Ink used in head cleaning, etc. is stored in the waste ink tank on the lower right side of the machine. This machine counts the accumulated amount of discharged ink. When that reaches a specified amount, the machine displays a confirmation message. (When this message is displayed, consider the replacement of the waste ink tank.)



- The message is displayed when it reaches 80% (1.6L) of the 2L tank.

### Confirmation Message in LOCAL

- 1 The warning message “Check waste ink” is displayed.
- 2 Check the state of the waste ink tank
  - When it is different from the actual amount, press   and correct.
  - When you correct (80%), press the **[ENTER]** key to return to LOCAL.
  - When you replace (disposal) and clear the count, perform the procedures in “Replace the waste ink tank with another”. (P.4-13)

## Replace the waste ink tank with another

**1** The warning message "Check waste ink" is displayed.

**2** Press the **FUNC2** (MAINT.) key.

**3** Check the state of the waste ink tank.

**4** If the amount of waste ink needs to be adjusted, press the **ENTER** key.

- Compare the amount of waste ink shown on the display and the amount you visually confirmed. If there is no major problem with the value shown on the display, instead of the [ENTER] key, press the [END] key and proceed to Step 6.

**5** Press **▲** **▼** to adjust the level, and press the **ENTER** key.

**6** Remove the waste ink tank.

- (1) Pull the projection of the waste ink tank holder to open the holder.

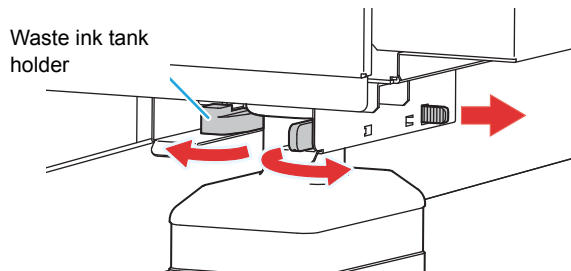

- (2) Pull it frontward to remove by holding the waste ink tank handle.

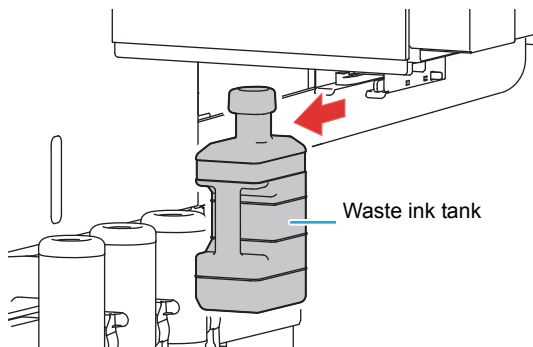

- Put a cap on the waste ink tank removed.

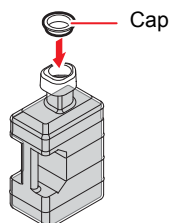

**7** Replace the waste ink tank.

- (1) Prepare a new waste ink tank.  
 (2) Insert the waste ink tank by holding a handle of the tank.

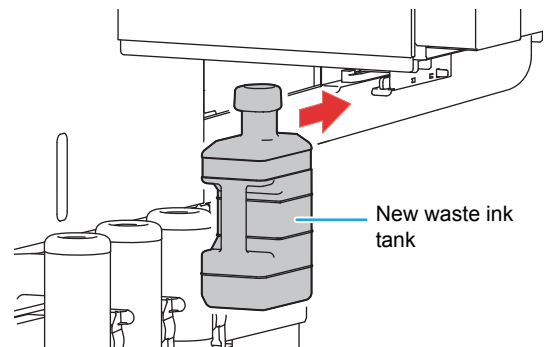

- Waste ink is equivalent to waste oil of industrial waste. Request an industrial waste disposal company for disposal of waste ink.



**8** Press the **ENTER** key.

- The ink discharging amount that is controlled by the machine is reset and the message is cancelled.



## Replacing the waste ink tank before the waste ink tank confirmation message is displayed

if you replace the waste ink tank before the waste ink tank confirmation message is displayed (before the 2L tank is 80% (1.6L) full), set the waste ink information to 0% in the Information menu.

- 1** Perform steps 6 through 9 in "Replace the waste ink tank with another" (P.4-13) to empty the waste ink tank.
- 2** Press the **FUNC1** (MENU)  **ENTER** key in LOCAL.
  - MAINTENANCE MENU will be displayed.
- 3** Press  4 times, and press the **ENTER** key.
  - "INK TANK EXCHANGE" will be selected.
- 4** Waste ink tank information is displayed.
- 5** Press the **FUNC2** (v) .
  - The reset screen for the waste ink tank amount will be displayed.
- 6** Press the **ENTER** key.
  - The waste ink tank amount that is managed in this machine will be reset.

## Refilling antifreeze mixed water

To cool the LED UV unit, put antifreeze mixed water into the cooling water tank in the cooling device.

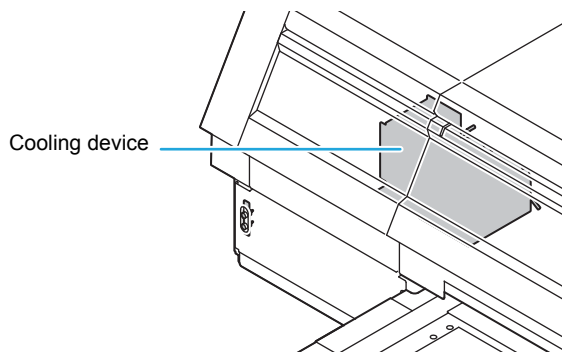

### Note on refill



- When only water is supplied to the cooling water tank without antifreeze liquid, it may damage the UV unit by freeze.
- When only antifreeze liquid is supplied to the cooling water tank without water, the machine does not work properly, and may cause an error.
- If water in the cooling water tank frequently becomes insufficient, contact a distributor in your district or our office.



- Dispose of the waste water mixed with antifreeze liquid pursuant to the regulations of your district.

### Note on antifreeze mixed water



To make mixed water, be sure to use the potable water meeting one of the following conditions:

- Calcium content: 1 mg/100 ml (10 mg/L) or less
- Hardness : 60 mg/L or less
- Distilled water (Purified water)
- Water and antifreeze liquid compound ratio should be 2(water) to 1(Antifreeze liquid). Or use our specialized antifreeze mixed water (SPC-0783).
- Use it within one week when you make mixed water. The mixed water that one week or more passed after it makes it is never used for this machine regardless of use/unused. Moreover, do not add to the mixed water newly made.



## ● Precautions in handling the antifreeze liquid



- Be sure to wear goggle and gloves for handling the antifreeze liquid.



- Use the recommended antifreeze liquid (SPC-0394) by Mimaki. If not, the cooling device may be broken. (Supplied antifreeze liquid : 1000cc x 2 bottles)
- Do not touch the antifreeze liquid directly. If the antifreeze liquid settles on your skin or clothes, immediately wash it off with soap and water. If you get antifreeze liquid in your eyes, immediately wash your eyes with a lot of clean water. Then, consult a doctor as soon as possible.
- Store antifreeze liquid in a dark and cold place.
- Store antifreeze liquid in a place that is out of the reach of children.
- When discarding antifreeze liquid which is no longer needed, entrust them to an industrial waste disposal contractor, clarifying their contents.
- Before using antifreeze liquid, be sure to read the Material Safety Data Sheet (MSDS).



- Prepare a tank with a cap to put in the waste water from cooling water tank.
- When water in the cooling water tank is low, a warning message "WATER LACK" is displayed. In this case, refill antifreeze water in the way shown as the next page.

## Refill antifreeze mixed water

If an error of lack of water, refill antifreeze mixed water.

### 1 Uncover the feed-water inlet and the air vent.

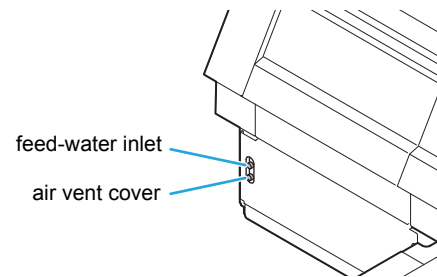

### 2 Remove all remaining water in the tank.

- (1) Remove all water in the tank with a provided syringe from the feed-water inlet.
- (2) Put the removed water into the tank with a cap, and discard it.

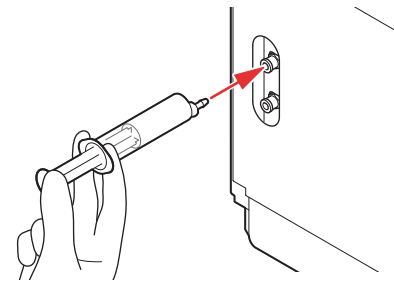

### 3 Made mixed water (antifreeze liquid: 1, water: 2) in the attached reservoir and move it to the attached syringe.



**4** Refill antifreeze mixed water.

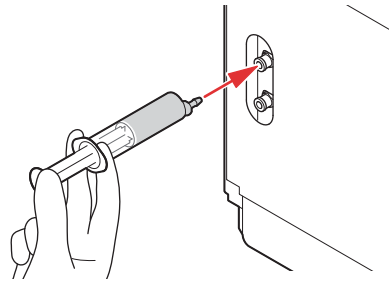

- Fill the antifreeze mixed water from the feed-water inlet.
- Put the liquid of 50ml into the syringe, and put it into the device. Repeat this 11 times to fill up (550ml).

**important!**

- Be aware that if you put in too much antifreeze mixed water, it may leak from the cooling water tank.

**5** Close the feed-water inlet and the air purge cover.

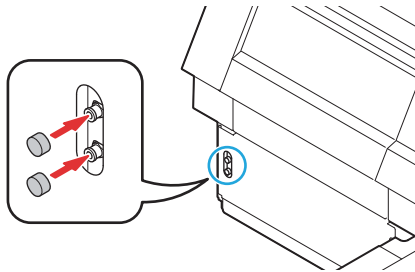

# Chapter 5

## Troubleshooting



### This chapter

describes the corrective measures to be taken for a phenomenon suspected to be trouble and the procedures to clear the error number displayed on the LCD.

Troubleshooting .....	5-2
Power does not turn on .....	5-2
The machine does not start printing .....	5-2
Image quality is poor .....	5-2
Nozzle is clogged .....	5-3
Ink bottle warning appears .....	5-3
Warning / Error Messages .....	5-4
Warning messages .....	5-4
Error messages .....	5-6

# Troubleshooting

Take appropriate actions as described below before taking the trouble as a failure.  
If still the problem is not solved after troubleshooting, contact your dealer or an office of MIMAKI.

## Power does not turn on

In most cases, this is due to improper connection of the power cable for the machine or computer. Check that the power cable is connected properly.

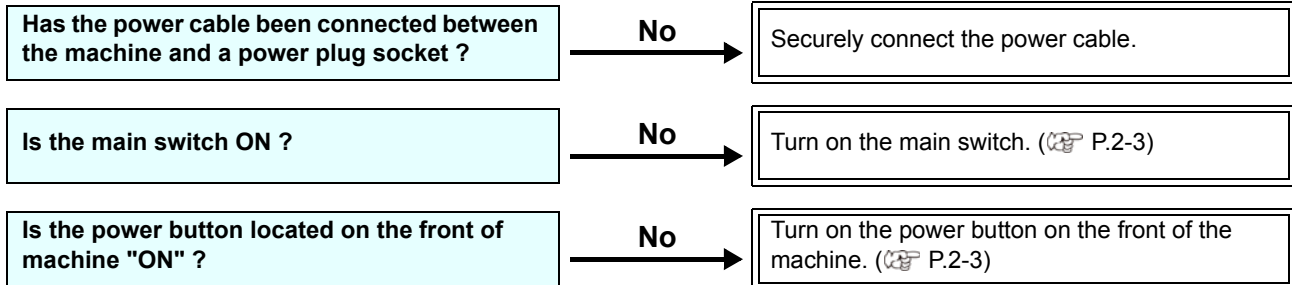

## The machine does not start printing

This occurs when the data is not being transmitted to the machine properly.  
It can also occur when the printing function does not work properly or the media is not set correctly.

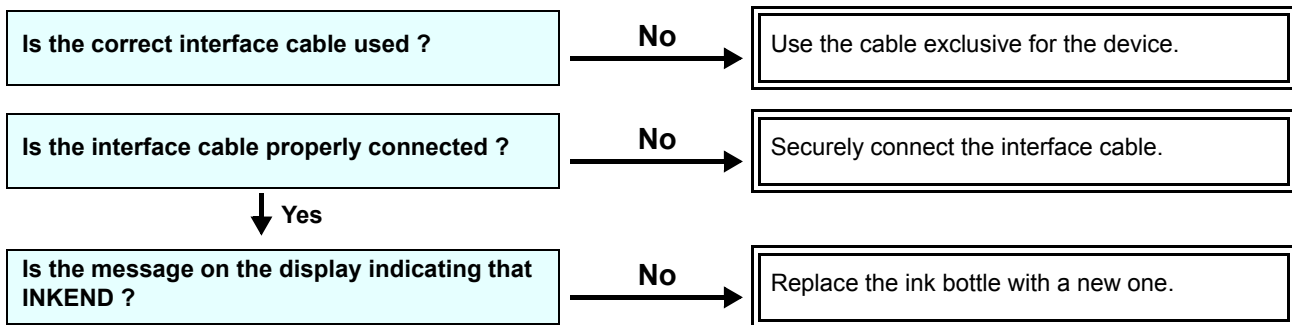

## Image quality is poor

This section describes the corrective actions to be taken in case the image quality is not satisfactory.  
Take remedy for particular problems with image quality. If the remedy does not work, contact your dealer or an office of MIMAKI.

Phenomenon	Measures
White lines / blur / dark stripes (in the direction of travel of the heads)	(1) Execute the head cleaning. (☞ P.2-7) (2) Perform maintenance of the inside of the station. (☞ P.4-6) (3) Execute the [FEED COMP.] function. (☞ P.3-8)
Characters are double- or triple-printed in the media feed direction	(1) Execute the [FEED COMP.] function. (☞ P.3-8)
Ink drops falling on media during printing	(1) Execute the wiper cleaning. (☞ P.4-6) (2) Execute the ink cap cleaning. (☞ P.4-6) (3) Clean around the head. (☞ P.4-8) (4) Execute the head cleaning [Normal]. (☞ P.2-7) (5) Set a shorter interval of Interval Wiping operation. (☞ P.4-10)

## Nozzle is clogged

When nozzle missing is not dissolved even after the head cleaning referring to P.2-7, make sure the following operations.

- **Recovery the nozzle by the operations of P.4-9.**

## Ink bottle warning appears

If an ink bottle trouble is detected, a warning message appears.

None of printing, cleaning and all the other operations that use ink is available.

If an abnormality occurs, perform the following procedures:

- Check the ink amount in the ink bottle and if the ink amount is not enough, add ink.

**Important!**

- Once ink tank trouble is displayed, do not leave the ink bottle without replacing it for a long time; otherwise, the machine will lose the nozzle missing prevention function.  
If nozzles are clogged, the machine must be repaired by MIMAKI's service engineer.

## Warning / Error Messages

If some trouble occurs, the buzzer sounds and the display shows a corresponding error message. Take an appropriate remedy for the displayed error.

### Warning messages

#### Errors when performing operations

Message	Cause	Solution
OPERATION	Incorrect operation is performed on the operation panel.	<ul style="list-style-type: none"> <li>Operate this machine correctly.</li> </ul>
DATA REMAIN	Unfinished printing data still remains.	<ul style="list-style-type: none"> <li>Clear the data.</li> </ul>

#### Message displayed in LOCAL

Message	Cause	Solution
INK NEAR END	There is little ink in the supply unit.	<ul style="list-style-type: none"> <li>Check the ink bottle for the displayed color. The ink in the bottle will end soon.</li> </ul>
INK END	No ink remains in the ink bottle for the displayed color.	<ul style="list-style-type: none"> <li>Replace the ink bottle and the IC chip for the displayed color with new ones.</li> </ul>
Expiration	The expiration date of an ink bottle has passed. (From the first day to the end of the month following the expiration)	
Expiration (1M)	The expiration date of an ink bottle has passed. (From the first day to the end of the month following the month following the expiration)	
Expiration (2M)	The expiration date of an ink bottle has passed. (3 months or more after expiration)	
INK TYPE	The types of the installed ink bottle and the IC chip are different.	<ul style="list-style-type: none"> <li>Check the types of the installed ink bottle and the installed IC chip for the displayed color. Install the ink bottle and the IC chip of the same type.</li> </ul>
Color of INK	The color of the installed IC chip is incorrect.	<ul style="list-style-type: none"> <li>Check if the displayed color matches the colors of the installed ink bottle and installed IC chip.</li> </ul>
NON-ORIGINAL	Not for a genuine Mimaki ink.	<ul style="list-style-type: none"> <li>Use a genuine Mimaki ink bottle and a genuine Mimaki IC chip.</li> </ul>
NON INK IC	Cannot check the ink IC chip.	<ul style="list-style-type: none"> <li>Insert the IC chip for the displayed color. If the message still appears, contact our service desk or your local distributor to call for service.</li> </ul>
!WORK High	An obstacle is detected.	<ul style="list-style-type: none"> <li>An obstacle was detected. Lower the table so that this warning disappears</li> </ul>
WATER LACK	The level of water in the cooling water tank is low.	<ul style="list-style-type: none"> <li>Refer to "Refill antifreeze mixed water" to refill the cooling water.</li> </ul>
!WS INKTANK CHK	The waste ink tank is full.	<ul style="list-style-type: none"> <li>Execute the station maintenance and dispose of the ink in the waste ink tank.</li> </ul>
CLEANING WIPER	It is time to clean the wiper or replace it with a new one.	<ul style="list-style-type: none"> <li>Execute the station maintenance and clean the wiper.</li> </ul>

Message	Cause	Solution
CAP CLEANING	The cap is not clean.	<ul style="list-style-type: none"> <li>Execute the carriage out of the station maintenance, and clean the cap.</li> </ul>
!CHECK LED UV LEVEL	The LED lamp has been used for a certain period.	<ul style="list-style-type: none"> <li>Check illuminance of the LED UV lamp. If it is lower than the set value, replace the lamp.</li> </ul>
Preservation Failure	Cannot write the remaining ink amount in the ink IC chip.	<ul style="list-style-type: none"> <li>Remove and set the IC chip again to rewrite. If the error does not disappear, replace with a new IC chip.</li> </ul>
NOT FILLUP	The ink bottle has not been filled with ink.	<ul style="list-style-type: none"> <li>Fill up ink of the displayed color.</li> </ul>
NCU CONNECT	The NCU unit is not connected. The nozzle check function cannot be used.	<ul style="list-style-type: none"> <li>Turn off the main power to the machine and turn it on after a while. If the same error message appears, contact our service desk or your local distributor to call for service.</li> </ul>
REPLACE NCU	The NCU sensor sensitivity is too low to correctly judge nozzle missing. The nozzle check function cannot be used.	<ul style="list-style-type: none"> <li>NCU replacement is necessary. Contact our service desk or your local distributor to call for service.</li> </ul>
REPLACE NCU INK PAD	The NCU ink pad is full.	<ul style="list-style-type: none"> <li>It is necessary to replace the NCU ink pad. Contact our service desk or your local distributor to call for service.</li> </ul>
NCU SENSOR LEVEL LOW	The NCU sensor sensitivity is falling.	<ul style="list-style-type: none"> <li>Replacement of the NCU is recommended.</li> <li>Contact our service desk or your local distributor to call for service.</li> </ul>
NCU Sensitivity Error H	Cannot adjust the sensor sensitivity.	
NCU Sensitivity Error L		

## Error messages

When an error message is displayed, eliminate the error according to the chart below.

If the same error message appears again, contact your dealer or an office of MIMAKI to call for service.

Message	Cause	Solution
ERROR 108 HD CONNECT [1234 ]	Abnormal connection of the print head	<ul style="list-style-type: none"> <li>• Turn off the power button to the machine and turn it on after a while.</li> <li>• If the same error message appears again, contact your local distributor to call for service.</li> </ul>
ERROR 108 HD THERMIS [1234 ]	Abnormal temperature of the print head	
ERROR 108 HD TYPE [1234 ]	The print head has been broken.	
ERROR 122 CHECK :SDRAM	The capacity of the PRAM is insufficient when updating the FW version (fw_updmsg).	
ERROR 128 HDC FIFO OVER	Control circuit board is defective.	
ERROR 128 HDC FIFO UNDER		
ERROR 129 BATTERY EXCHANGE	The battery life end of the internal clock is detected.	<ul style="list-style-type: none"> <li>• Contact your local distributor to call for service.</li> </ul>
ERROR 12a HDC SPEED [12 ]	Ink discharge control error	<ul style="list-style-type: none"> <li>• Turn off the power button to the machine and turn it on after a while.</li> <li>• If the same error message appears again, contact your local distributor to call for service.</li> </ul>
ERROR 12e HeadFaild /HDC[**]	The print head has been broken.	
ERROR 12f HDC I/F xxxxxxxx	Control circuit board is defective.	
ERROR 130 HD DATA SEQ		
ERROR 148 E-LOG SEQ		
ERROR 151 Main PCB V1R2	An error occurred in the main power.	
ERROR 152 Main PCB V2R5		
ERROR 153 Main PCB V3R3		
ERROR 154 Main PCB V05		
ERROR 155 Main PCB V36-1		
ERROR 156 Main PCB V5B		
ERROR 157 Main PCB VTT		
ERROR 158 Main PCB V362		
ERROR 16e Main PCB V3R3B		
ERROR 18a Main PCB V_CORE		
ERROR 18b Main PCB V1R5B		
ERROR 18c Main PCB V12		



Message	Cause	Solution
ERROR 201 COMMAND	Abnormal communication between PC and printer	<ul style="list-style-type: none"> <li>• Check the USB cable connection. Use a USB cable conforming to the standard.</li> </ul>
ERROR 202 PARAMETER		
ERROR 203 Ment Command		
ERROR 206 PRINTING MODE		<ul style="list-style-type: none"> <li>• Check the USB cable connection. Use a USB cable conforming to the standard.</li> <li>• Check output conditions.</li> </ul>
ERROR 304 USB INIT ERR	USB device error.	
ERROR 305 USB TIME OUT		
ERROR 401 MOTOR X	An excessive load was applied to the X motor.	<ul style="list-style-type: none"> <li>• Turn off the power button to the machine and turn it on after a while.</li> <li>• If the same error message appears again, contact your local distributor to call for service.</li> </ul>
ERROR 402 MOTOR Y	An excessive load was applied to the Y motor.	
ERROR 403 X CURRENT	An error due to an excessive current of the X motor was detected.	
ERROR 404 Y CURRENT	An error due to an excessive current of the Y motor was detected.	
ERROR 42f Adjust Pin	The cover of the adjust pin is not set correctly.	<ul style="list-style-type: none"> <li>• Set the cover correctly.</li> </ul>
ERROR 445 SUPPLY Pchange:	The supply pump should be replaced.	<ul style="list-style-type: none"> <li>• Replace the supply pump.</li> </ul>
ERROR 446 VACUUM Pchange:	The vacuum pump should be replaced.	<ul style="list-style-type: none"> <li>• Replace the vacuum pump.</li> </ul>
ERROR 465 X MOTOR CTRL Err	X motor control error	<ul style="list-style-type: none"> <li>• Turn off the power button to the machine and turn it on after a while.</li> <li>• If the same error message appears again, contact your local distributor to call for service.</li> </ul>
ERROR 466 Y MOTOR CTRL Err	Y motor control error	
ERROR 467 Z MOTOR CTRL Err	Z motor control error	
ERROR 509 HDC POSCNT	An error occurred in the control position.	
ERROR 50a Y ORIGIN	Y-origin could not be detected.	
ERROR 50e HEAD TEMP [123456 ]	The print head has been broken.	
ERROR 50f L-SCALE BLACK	Abnormal linear scale.	
ERROR 510 X ORIGIN	X-axis origin error	
ERROR 511 Z ORIGIN	Z-axis origin error	
ERROR 601 INK BOTTLE NEAR END	"INK NEAR END" (very little ink remains in the bottle)	<ul style="list-style-type: none"> <li>• Replace the ink bottle and the IC chip with new ones.</li> </ul>
ERROR 602 INK BOTTLE END	"INK END" (no ink remains in the bottle)	
ERROR 603 NO INK BOTTLE	No ink bottle (no ink bottle is installed).	<ul style="list-style-type: none"> <li>• Install the ink bottle and the IC chip.</li> </ul>
ERROR 606 NON INK IC	Ink IC reading error.	<ul style="list-style-type: none"> <li>• Remove and set the IC chip and try again.</li> </ul>

Message	Cause	Solution
ERROR 607 CAP CLEANING	Time to clean the cap	<ul style="list-style-type: none"> <li>Perform the station maintenance, and clean the cap.</li> </ul>
ERROR 614 Preservation Failure	Ink IC writing error.	<ul style="list-style-type: none"> <li>Remove and set the IC chip and try again.</li> </ul>
ERROR 616 Ink Fillup End	The ink bottle has already been filled with ink.	<ul style="list-style-type: none"> <li>Try again after the ink is discharged.</li> </ul>
ERROR 617 SUBTANK SNN :123456	The surface level of the subtank rose abnormally.	<ul style="list-style-type: none"> <li>Perform "Overflow" of the maintenance. (☞ P.4-12) Also make sure the ink remaining in the ink bottle.</li> <li>Even if you perform, it may be displayed, contact your local distributor to call for service.</li> </ul>
ERROR 618 TANK level H :123456	The sub tank sensor High does not change though a certain amount of ink has been consumed.	
ERROR 619 TANK level L :123456	Though a certain amount was consumed, there is no change in the sub tank sensor Low	
ERROR 61a InkOverflow :123456	Ink has entered the air tank.	
ERROR 61b SUPPLY INK :1234	Ink could not be supplied to the subtank.	
ERROR 61c NEGATIVE P. CONTROL	Starting of the negative pressure control has an abnormality.	
ERROR 61d NEGATIVE P. Not Enough	The negative pressure cannot be kept properly. (On the positive side)	
ERROR 61e NEGATIVE P. OVER	The negative pressure cannot be kept properly. (On the negative side)	
ERROR 61f POSITIVE P. CONTROL	Starting of the positive pressure control has an abnormality.	
ERROR 620 POSITIVE P. No t Enough	The positive pressure cannot be kept properly. (On the positive side)	
ERROR 621 POSITIV P. OVER	The positive pressure cannot be kept properly. (On the negative side)	
ERROR 629 Expiration:1MONTH	The expiration date of an ink bottle has passed. (From the first day to the last day of the month following the month after expiration.)	
ERROR 621a Expiration:2MONTH	The expiration date of an ink bottle has passed. (3 months or more after expiration.)	
ERROR 64c NCU ERROR	Printing stopped because an error occurred during the nozzle check.	<ul style="list-style-type: none"> <li>Turn off the power button to the machine and turn it on after a while.</li> <li>If the same error message appears again, contact your local distributor to call for service.</li> </ul>
ERROR 650 NCU CONNECT	The NCU unit is not connected.?	
ERROR 651 REPLACE NCU	The NCU sensor sensitivity is too low to correctly judge nozzle missing. The nozzle check function cannot be used.	
ERROR 652 NCU NZK CHK (HW)	The hardware cannot perform sampling of the discharge patterns of the NCU.	<ul style="list-style-type: none"> <li>Check the nozzle condition. If there is plenty of deflection and/or nozzle missing, clean and restore the affected nozzles. (☞ P.2-7)</li> <li>If the same error message appears, contact our service desk or your local distributor to call for service.</li> </ul>
ERROR 653 NCU NZK CHK (MARK)	The discharge patterns of the NCU are analyzed and abnormal discharge is identified that does not meet the pattern criteria.	
ERROR 654 NCU CENTER POS	Detecting the center position of the NCU failed.	
ERROR 655 NCU FLUSH POS	Detecting the optimal position of the NCU for the sensor sensitivity failed.	
ERROR 656 NCU SN ADJST	Sensor sensitivity adjustment has failed.	

Message	Cause	Solution
ERROR 657 REPLACE NCU INK PAD	The NCU ink pat is full.	<ul style="list-style-type: none"> <li>• Contact our service desk or your local distributor to call for service.</li> </ul>
ERROR 658 NCU SENSOR LV LOW	The NCU sensor sensitivity is falling.	<ul style="list-style-type: none"> <li>• Replacement of the NCU is recommended.</li> <li>• Contact our service desk or your local distributor to call for service.</li> </ul>
ERROR 702 THERMISTOR	The thermistor sensor of a heater is defective.	<ul style="list-style-type: none"> <li>• Turn off the power button to the machine and turn it on after a while.</li> <li>• If the same error message appears again, contact your local distributor to call for service.</li> </ul>
ERROR 708 UV THERMISTOR BRK	The thermistor (thermal sensor) in the UV unit is disconnected.	
ERROR 70a LED UV Current	The LED UV unit is broken or abnormal current is detected.	
ERROR 70c UV UNIT BRK	The LED UV unit is disconnected.	
ERROR 70d UV UNIT TMP ERROR	The thermistor (thermal sensor) in the UV unit is disconnected.	
ERROR 901 OPERATION	Incorrect operation is performed on the operation panel.	<ul style="list-style-type: none"> <li>• Operate this machine correctly.</li> </ul>
ERROR 90d NO HEAD SELECT	No head is specified.	<ul style="list-style-type: none"> <li>• Specify a head and try again.</li> </ul>

## SYSTEM HALT

Message	Solution
SYSTEM HALT (*) 000 :MESSAGE	Turn off the main power to the machine and turn it on after a while. Check the number and contact your local distributor to call for service. ("000" is the error No.)



# Chapter 6

## Appendix



### **This chapter**

contains the lists of the specifications and functions of this machine.

Specifications .....	6-2
Machine specifications .....	6-2
Ink specifications .....	6-3
Setting orders of ink bottles .....	6-4
Sheet for inquiry .....	6-5

# Specifications

## Machine specifications

Item		UJF-7151 plus
Print head	Method	Drop-on-demand piezoelectric print heads
	Specification	6 head staggered
Resolution		x-dpi: 600, 900, 1200 y-dpi: 600, 1200
Drawing mode	600 x 600	4, 8 pass
	600 x 900	6, 12 pass
	1200x1200	8, 16 pass
Usable inks		Exclusive UV curing ink (Genuine ink) Bk, C, M, Y, W, P, CL (CL is LH-100 only.)
Ink supply		Supplying 1L x 6 bottles
Usable media	Size	712x510mm
	Thickness	153mm
	Weight	10kg
Max. printing area		712x510mm
Distance accuracy	Absolute accuracy	Whichever the larger one of $\pm 0.3$ mm or $\pm 0.3$ % of the designated
	Reproducibility	Whichever the larger one of $\pm 0.2$ mm or $\pm 0.1$ % of the designated
Perpendicularity		$\pm 0.3$ mm/400mm
Media skew		5 mm or less / 10 m
Print gap adjustment		Table up/down mechanism by key
Head anticollision device		Head anticollision by obstacle sensor
UV unit		Water-cooling LED UV device x 1 (equipped with the head slider)
Waste ink tank		Bottle type ( 2,000 cc)
Interface		USB 2.0 (Ethernet 10 BASE/ 100 BASE/ 1000 BASE E-mail function, only "1000 BASE" connection is applicable for drawing.)
Command		MRL- V
Noise	during standby	Less than 55 dB (A) (FAST-A, Front & Rear & Left & Right 1 m)
	during continuous printing <sup>*1</sup>	Less than 65 dB (A)
	during discontinuous printing	Less than 75 dB (A)
Safety Standard		VCCI-Class A, FCC-Class A, UL 60950, CE Marking (EMC, Low Voltage Directive, Machinery Directive, RoHS Directive), CB Report, RoHS
Power		Single phase AC100 - 240 V +6% / -10% 50 / 60 Hz $\pm 1$ Hz
Power consumption		1300VA or less
Recommended Environment	Available temp.	20 °C to 35 °C
	Humidity	35 to 65% Rh (No condensation)
	Guaranteed temp.	20 °C to 25 °C
	Temperature change	$\pm 10$ °C / h or less
	Dust	Equivalent to normal office level
Highest operation height		2000 m
Weight		310 kg
Outside dimensions	Width	2193mm
	Depth	1572mm
	Height	1273mm

\*1. Operating Condition: Full load Measuring Method: According to clause 1.7.4.2 of Machinery Directive 2006/42/EC

## Ink specifications

Item		Specifications
Supply		1L Ink bottle
Color		Black ink Cyan ink Magenta ink Yellow ink White ink Clear ink (only LH100 ink) Primer ink (PR-200)
Ink capacity		1 liter
Shelf life		The period is printed on the ink bottle. Within three months after opening the package even in the available period.
Storage temperature	Storage	5 to 30°C (Storage at temperature of 30°C is permitted within a month.) Be sure to keep a vessel in the airtight condition. Be sure to keep a vessel in a dry, well-ventilated, cool and dark location.
	Transportation	1 to 60°C (Storage at temperature of 60°C is only permitted within 120 hours, and at temperature of 40°C is permitted within a month.) Avoid the condition lower than -0 °C and higher than 40 °C.

**Important!**

- Do not disassemble ink bottles and do not refill them with ink.
- Ink could freeze if kept in a cold place for an extended period.  
If the ink freezes, thaw it at room temperature (25°C) spending more than three hours before use.  
However, when you use the frozen ink, the printing quality becomes degraded due to altered ink. Store ink in the environment where ink may not freeze.

# Setting orders of ink bottles



- The order of the ink bottles that are set differs depending on the ink set that is used.

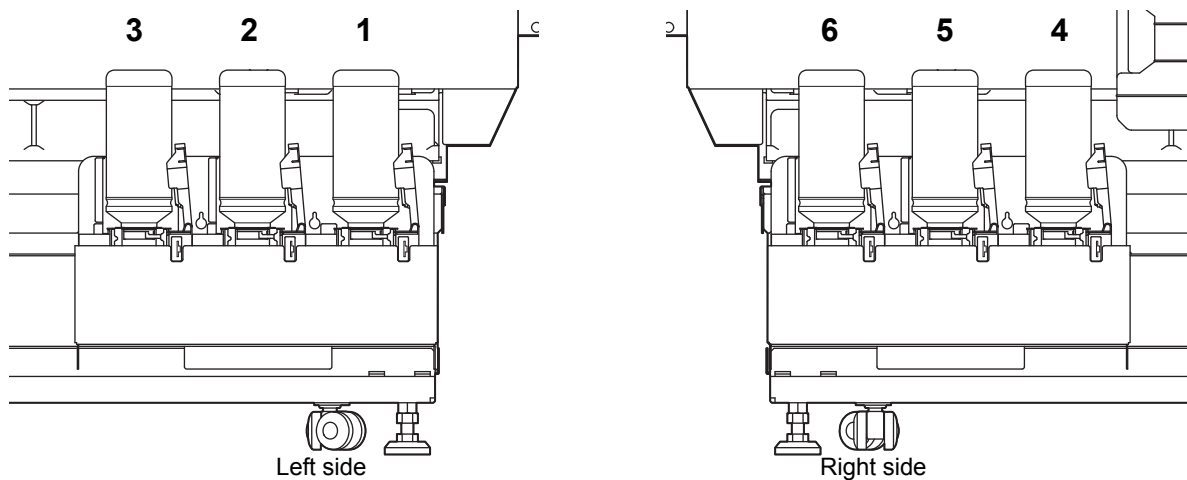

Ink type	Ink set	Ink arrangement					
		1	2	3	4	5	6
LH100	4 -color + Clear + White (Shipping)	W	CL	M	C	Y	K
	4 -color + W+ Primer	W	P	M	C	Y	K



# Sheet for inquiry

Use this sheet for troubles and abnormal functions of the machine.  
Fill in the following necessary items, and then fax the sheet to our sales office.

<b>Company name</b>	
<b>Person in charge</b>	
<b>Telephone number</b>	
<b>machine model</b>	
<b>Operating OS</b>	
<b>Machine information *1</b>	
<b>Error message</b>	
<b>Contents of inquiry</b>	

\*1. Refer to "Confirming Machine information" of "Convenient using" then fill in necessary information. (P.3-26)



# **UJF-7151 plus Operation Manual**

---

---

January, 2016

**MIMAKI ENGINEERING CO.,LTD.**

2182-3 Shigeno-otsu, Tomi-shi, Nagano 389-0512 JAPAN

---

---

D202901-12-15012016

